

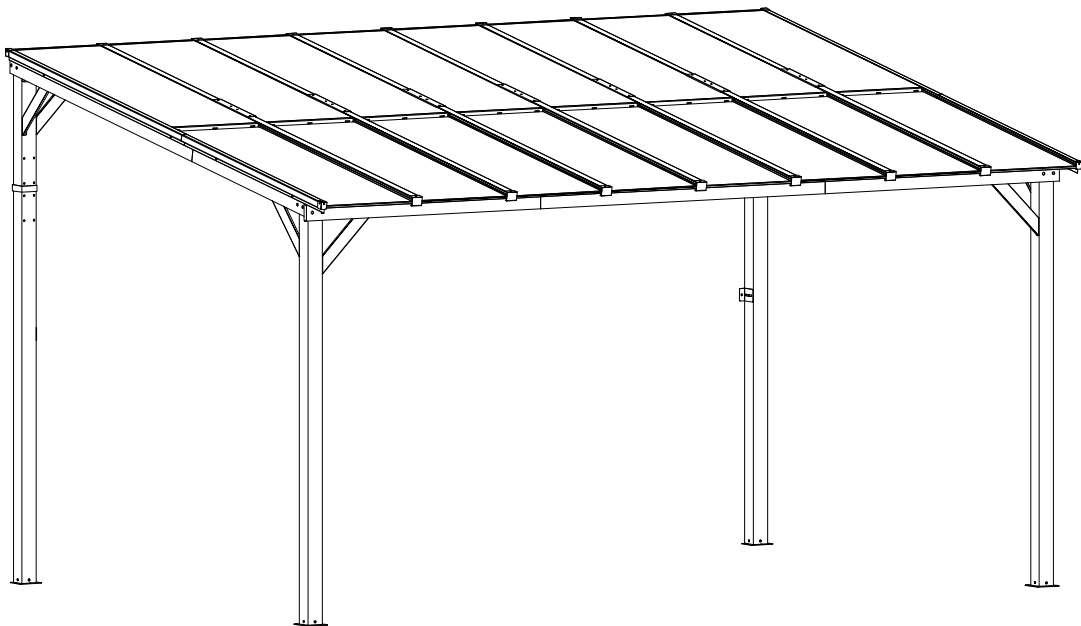

IN240900546V01_GL

84C-628V01



Tools Recommended

EN_IMPORTANT, RETAIN FOR FUTURE REFERENCE: READ CAREFULLY.

FR_IMPORTANT: A LIRE ATTENTIVEMENT ET À CONSERVER POUR CONSULTATION ULTÉRIEURE.

ES_IMPORTANTE, LEA Y GUARDE PARA FUTURAS REFERENCIAS.

PT_IMPORTANTE, RETER PARA REFERÊNCIA FUTURA: LEIA ATENTAMENTE.

DE_WICHTIG! SORFGFÄLTIG LESEN UND FÜR SPÄTERES NACHSCHLAGEN AUFBEWAHREN.

IT_IMPORTANTE! CONSERVARE IL PRESENTE MANUALE PER FUTURO RIFERIMENTO E LEGGERLO ATTENTAMENTE.

EN

IMPORTANT SAFETY NOTICE

Product is NOT INTENDED for the following:

- A safety barrier to prevent unsupervised access to pools, hot tubs, spas or ponds.
- As load bearing support for a building, structure, heavy objects or swings.
- Used in structures that trap wind, rain or snow that would create extra load on the product.

Accumulated snow must be removed from roof.

DO NOT climb or walk on roof for any reason.

Wear gloves to avoid injury from possible sharp edges of individual elements before assembly.

During installation, follow all safety warnings provided with your tools.

Some structures may require two or more people to install safely.

Check for underground utilities before digging or driving stakes into the ground!

It is important during assembly to closely follow the instructions, complete the assembly on a solid level surface and that you follow the instruction to square up, level and anchor the structure, this will reduce the gap at connections during assembly.

FR

AVIS IMPORTANT DE SÉCURITÉ

Le produit n'est PAS DESTINÉ à ce qui suit :

- Une barrière de sécurité pour empêcher l'accès non surveillé aux piscines, aux spas, aux cuves thermales ou aux étangs.
- Comme support de charge pour un bâtiment, une structure, des objets lourds ou des balançoires.
- Utilisé dans des structures qui retiennent le vent, la pluie ou la neige qui créeraient une charge supplémentaire sur le produit.

La neige accumulée doit être enlevée du toit.

NE PAS grimper ou marcher sur le toit pour quelque raison que ce soit.

Portez des gants pour éviter les blessures causées par d'éventuels bords tranchants des composants avant de procéder à l'assemblage.

Lors de l'installation, respectez tous les avertissements de sécurité fournis avec vos outils.

Certaines structures peuvent nécessiter l'intervention de deux personnes ou plus pour les installer en toute sécurité.

Vérifiez la présence de services publics souterrains avant de creuser ou de planter des piquets dans le sol !

Il est important, pendant tout le processus de montage, de suivre attentivement les instructions, de terminer l'assemblage sur une surface solide et plane et de suivre les instructions d'équerrage, de mise à niveau et d'ancrage de la structure, ce qui permettra de réduire les écarts au niveau des liaisons pendant le montage.

ES

AVISO IMPORTANTE DE SEGURIDAD

Manténgase alejado de las líneas eléctricas aéreas.

No coloque ni instale su tienda de campaña debajo de los árboles debido a posibles rayos o hundimiento de las ramas de los árboles en condiciones climáticas adversas. Para obtener las mejores condiciones en caso de viento fuerte, coloque el extremo estrecho de la tienda en la dirección del viento.

No dejes caer la tienda de campaña.

No haga rebotar ni golpee la bolsa de la tienda para sacarla, estas acciones podrían dañar el marco.

ESTE PRODUCTO REQUIERE UN MÍNIMO DE DOS PERSONAS PARA SU MONTAJE

Bajo ninguna circunstancia se debe utilizar este producto para cubrir automóviles, vehículos marinos o artículos similares.

PRECAUCIÓN: Vigile no pellizcarse los dedos durante el montaje y desmontaje de la tienda al unir las piezas del marco.

PT**AVISO DE SEGURANÇA IMPORTANTE**

O produto NÃO é DESTINADO ao seguinte:

- Uma barreira de segurança para impedir o acesso sem supervisão a piscinas, banheiras, spas ou lagos.
- Como suporte de carga para um edifício, estrutura, objectos pesados ou baloiços.
- Usado em estruturas que apanham vento, chuva ou neve que criariam carga extra sobre o produto.

A neve acumulada deve ser removida do telhado. NÃO subir ou caminhar no telhado por qualquer razão.

Usar luvas para evitar ferimentos causados por possíveis arestas vivas de elementos individuais antes da montagem.

Durante a instalação, siga todos os avisos de segurança fornecidos com as suas ferramentas. Algumas estruturas podem exigir a instalação segura de duas ou mais pessoas. Verifique a existência de utilidades subterrâneas antes de escavar ou de conduzir estacas no solo!

É importante durante a montagem seguir de perto as instruções, completar a montagem numa superfície sólida e nivelar e ancorar a estrutura, o que reduzirá a folga nas ligações durante a montagem.

DE**WICHTIGER SICHERHEITSHINWEIS**

Das Produkt ist NICHT für einen der folgenden Anwendungen bestimmt:

- Als Sicherheitsbarriere, die den unbeaufsichtigten Zugang zu Pools, Whirlpools, Spas oder Teichen verhindert.
- Als tragende Stütze für ein Gebäude, eine Struktur, schwere Gegenstände oder Schaukeln.
- Als Bestandteil einer Struktur verwendet werden, welche Wind, Regen oder Schnee abfangen, die eine zusätzliche Belastung für das Produkt darstellen würden.

Angesammelter Schnee muss vom Dach entfernt werden.

Aus keinem Grund darf das Dach bestiegen oder betreten werden.

Bitte tragen Sie stets geeignete Arbeitshandschuhe, um Verletzungen durch mögliche scharfe Kanten einzelner Elemente während der Montage zu vermeiden.

Befolgen Sie während des Installationsprozesses bitte sorgfältig alle Sicherheitswarnungen, die mit Ihren Werkzeugen geliefert werden.

Einige Strukturen können zwei oder mehr Personen erfordern, um sicher installiert zu werden.

Prüfen Sie vor dem Graben oder Eintreiben von Pfählen in den Boden, ob Erdkabel vorhanden sind!

Es ist wichtig, während der Montage die Anweisungen genau zu befolgen, Ihr Produkt auf einem festen und ebenen Untergrund aufzustellen und die Anweisung zum Aufrichten, Nivellieren und Verankern der Struktur zu befolgen, da dadurch der Spalt an den Verbindungen während der Montage verringert wird.

IT**IMPORTANTI PRECAUZIONI DI SICUREZZA**

Il prodotto NON è PROGETTATO per quanto segue:

- Una barriera di sicurezza per impedire l'accesso senza supervisione a piscine, vasche idromassaggio, spa o stagni.
- Supporto portante di edifici, strutture, oggetti pesanti o altalene.
- Parte di strutture che accumulano vento, pioggia o neve, in quanto creerebbero un carico extra sul prodotto.

La neve accumulata deve essere rimossa dal tetto.

NON salire o camminare sul tetto per nessun motivo.

Indossare guanti per evitare lesioni derivanti da spigoli vivi dei singoli componenti prima del montaggio.











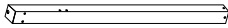

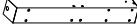
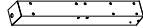
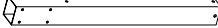
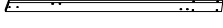

Durante l'installazione, seguire tutte le precauzioni di sicurezza fornite con gli strumenti.









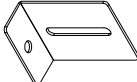

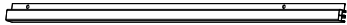







Alcune strutture possono richiedere due o più persone per essere installate in sicurezza.



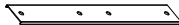

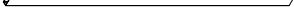

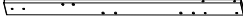
Controlla le utenze sotterranee prima di scavare o piantare pali nel terreno!

È importante che durante il montaggio vengano seguite attentamente le istruzioni, inoltre completare il montaggio su una superficie piana e solida e seguire le istruzioni per allineare, livellare e ancorare la struttura, in quanto questo ridurrà lo spazio necessario durante il montaggio.

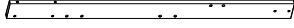
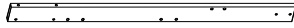









Part List

Description(Box A)	Label	Qty	Part Image
	A1	1	
	A2	1	
	A3	1	
	A4	1	
	A6	1	
	C7	1	
	C8	1	
	D7	2	
	E5	7	
	J2	6	
	M1	2	
	M2	2	
	P1	1	
	P2	1	
	P4	2	
	P5	7	
	P6	7	
	S	14	
	V	2	

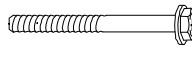
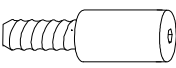
	W5	1	
	W6	1	
	W9	1	
Description(Box B)	Label	Qty	Part Image
	C5	1	
	C6	1	
	E6	7	
	H1	2	
	H2	2	
	H3	1	
	H4	1	
	H5	1	
	H6	1	
	J1	4	
	J3	14	
	J5	2	
	L3	16	
	L4	8	
	O1	1	
	O2	1	

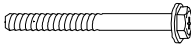
	O3	1	
	O4	1	
	Q1	16	
	T	2	
	W3	1	
	W4	1	
	W7	1	
	W8	1	

Hardware Pack

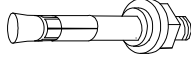
Description(Box B)	Label	Qty	Part Image
M4x16	AA	18+2	
M6	BB	28+2	
M6	DD	28+2	
M6x15	GG	198+10	
M6	HH	32+3	
M6x50	NN	28+2	
M6x35	KK	16+2	
	LL	16+3	
M6x75	JJ	7+1	
D8x180	PP	8	
M6	Z1	2	
M6	Z2	2	
M6x80	UU	10	

1



A1 1x



A2 1x

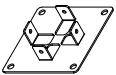

M2 2x

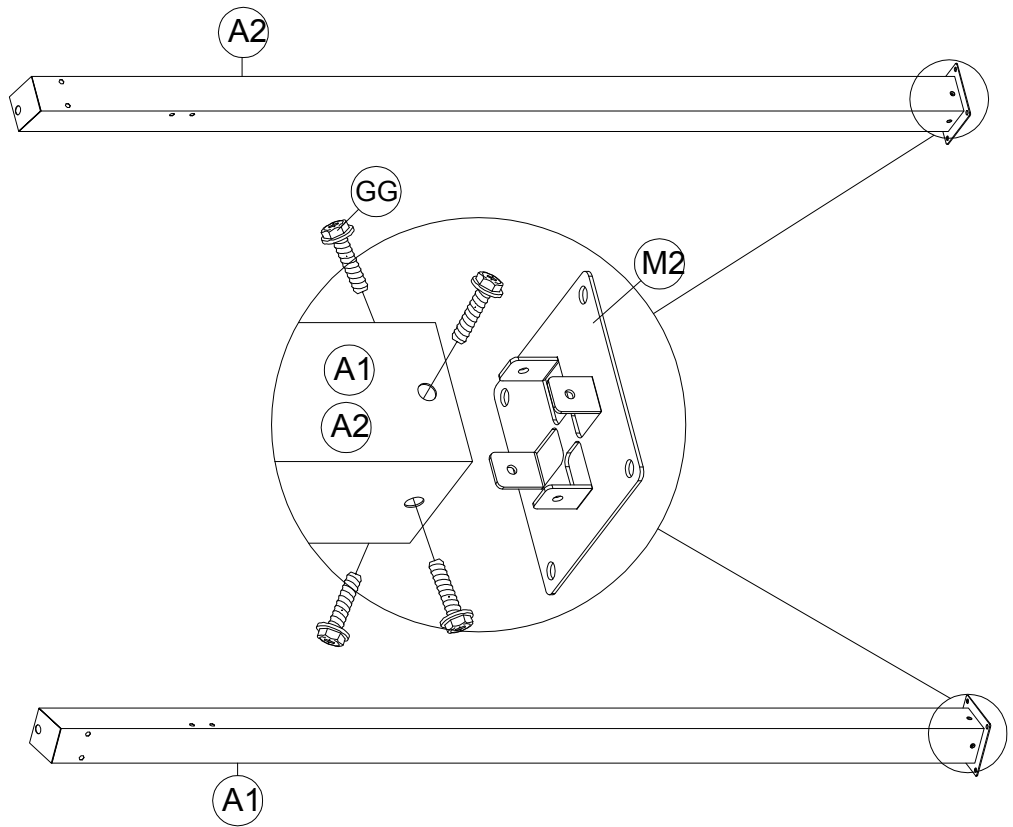

GG 8x

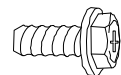

M6x15

2

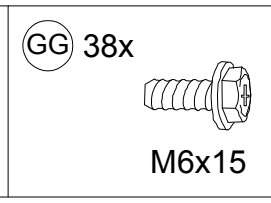
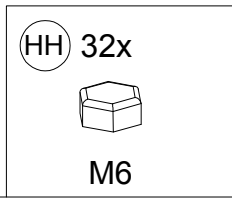
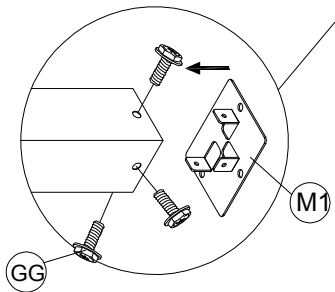
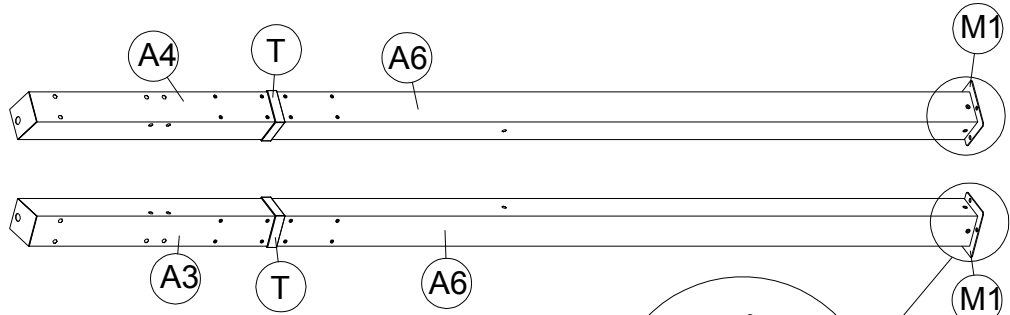
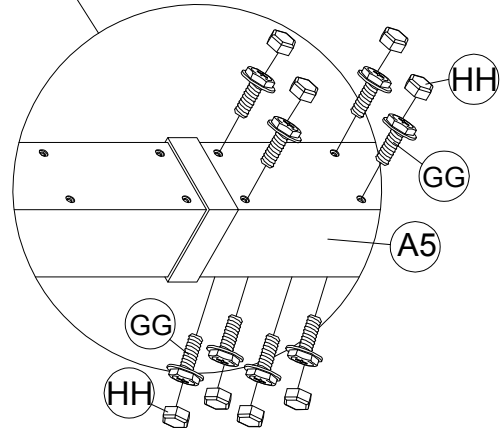
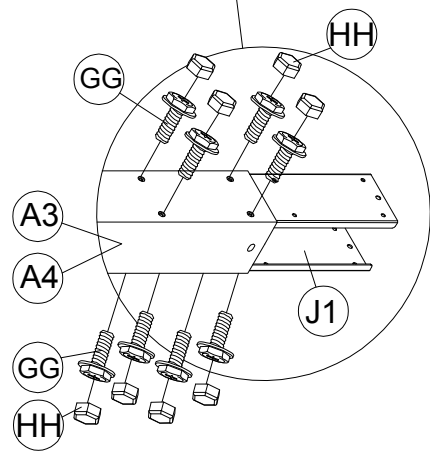
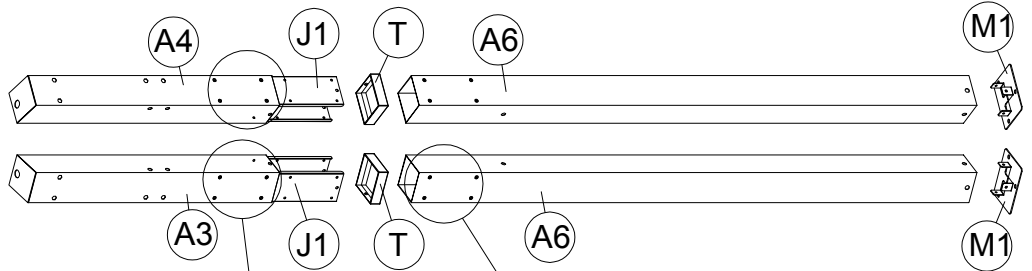
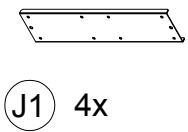
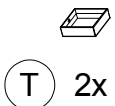
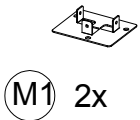
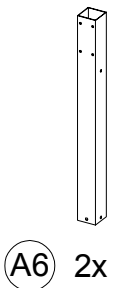
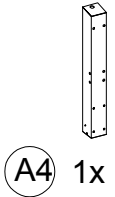
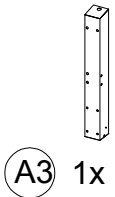

3



O2 1x



D7 1x



O1 1x

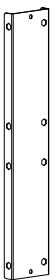

J2 2x

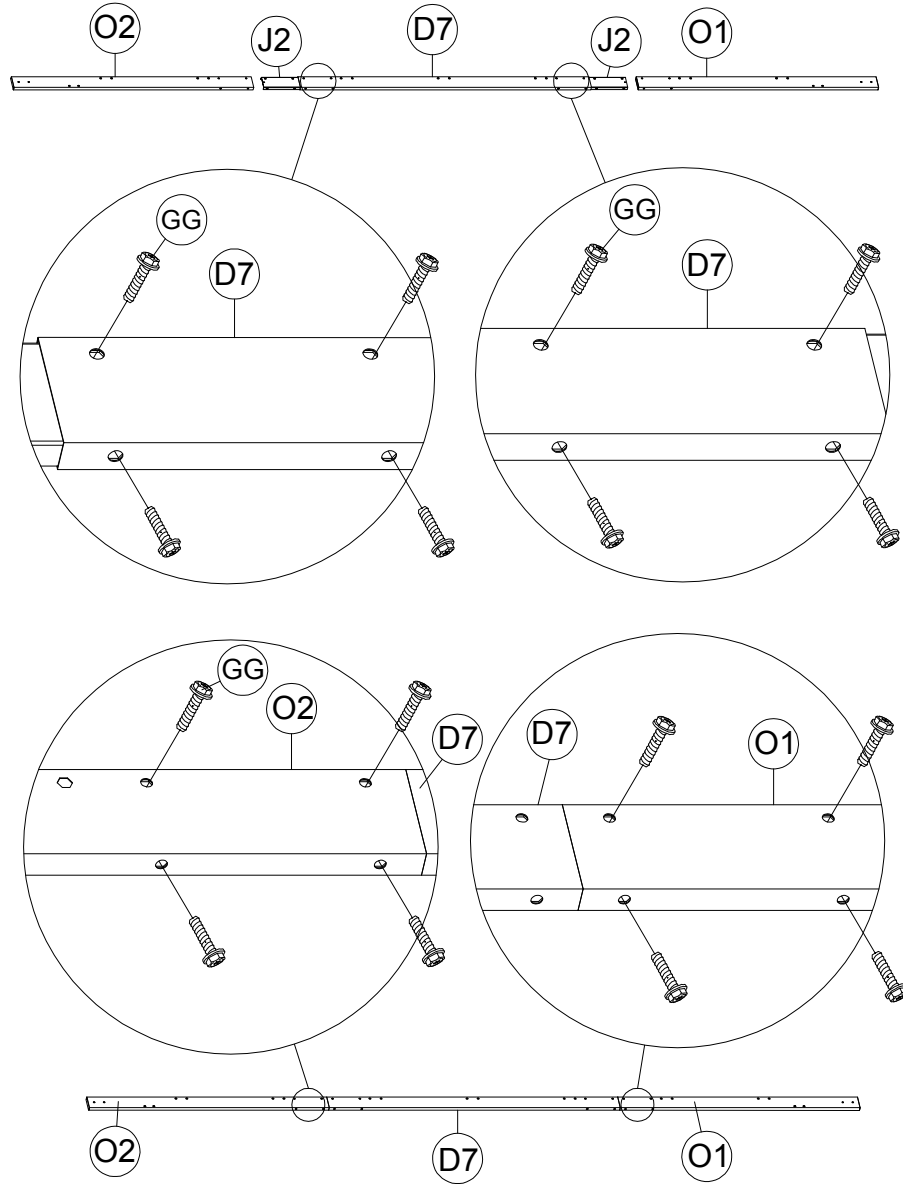

GG 16x

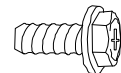

M6x15

4

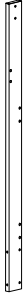

O4 1x



D7 1x



O3 1x

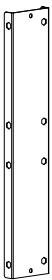

J2 2x

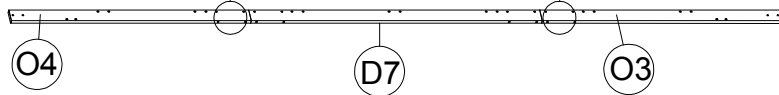
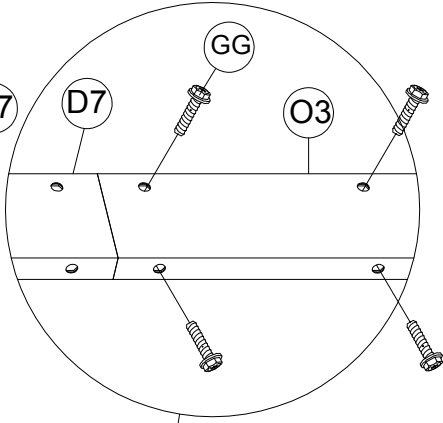
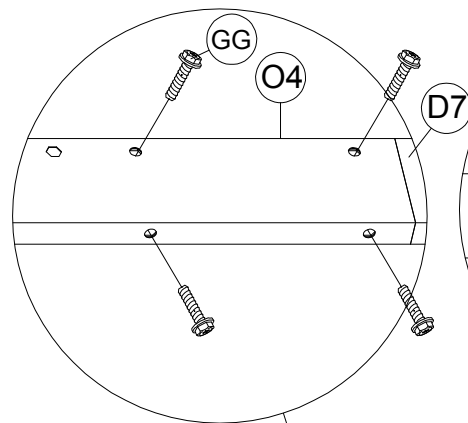
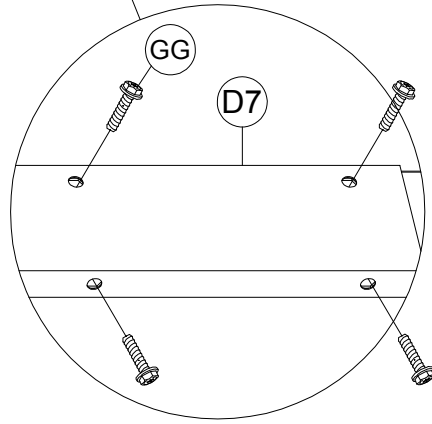
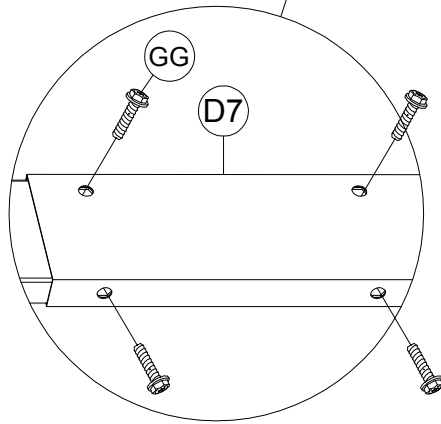
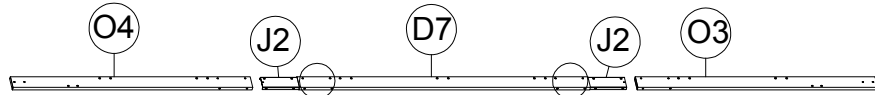

GG 16x

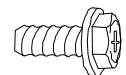

M6x15

5



C7 1x



C5 1x

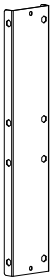

J2 1x

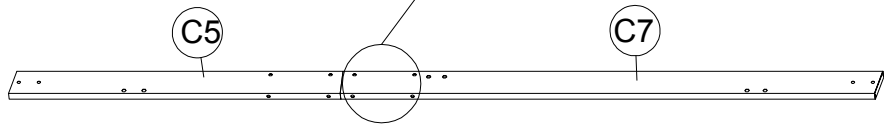
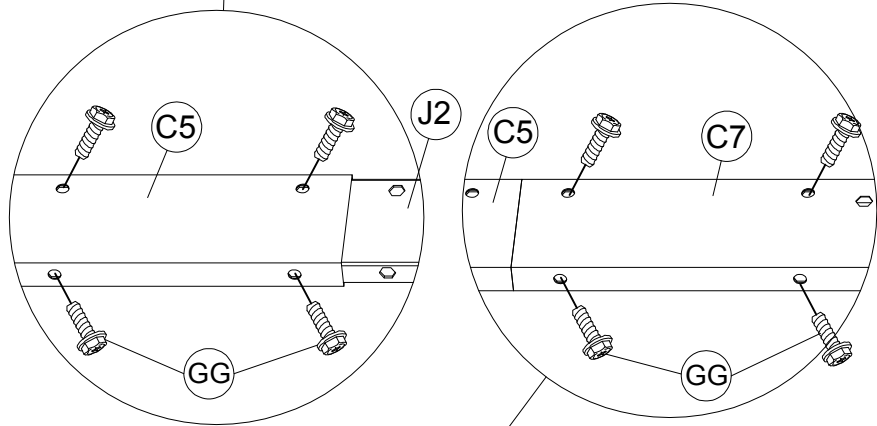
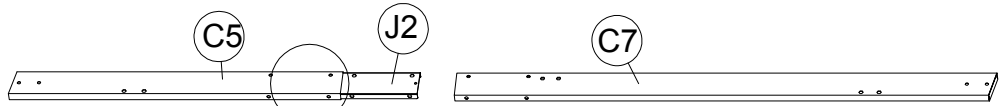

GG 8x

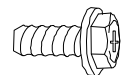

M6x15

6



C8 1x

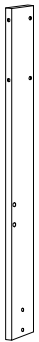

C6 1x

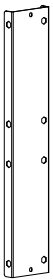

J2 1x

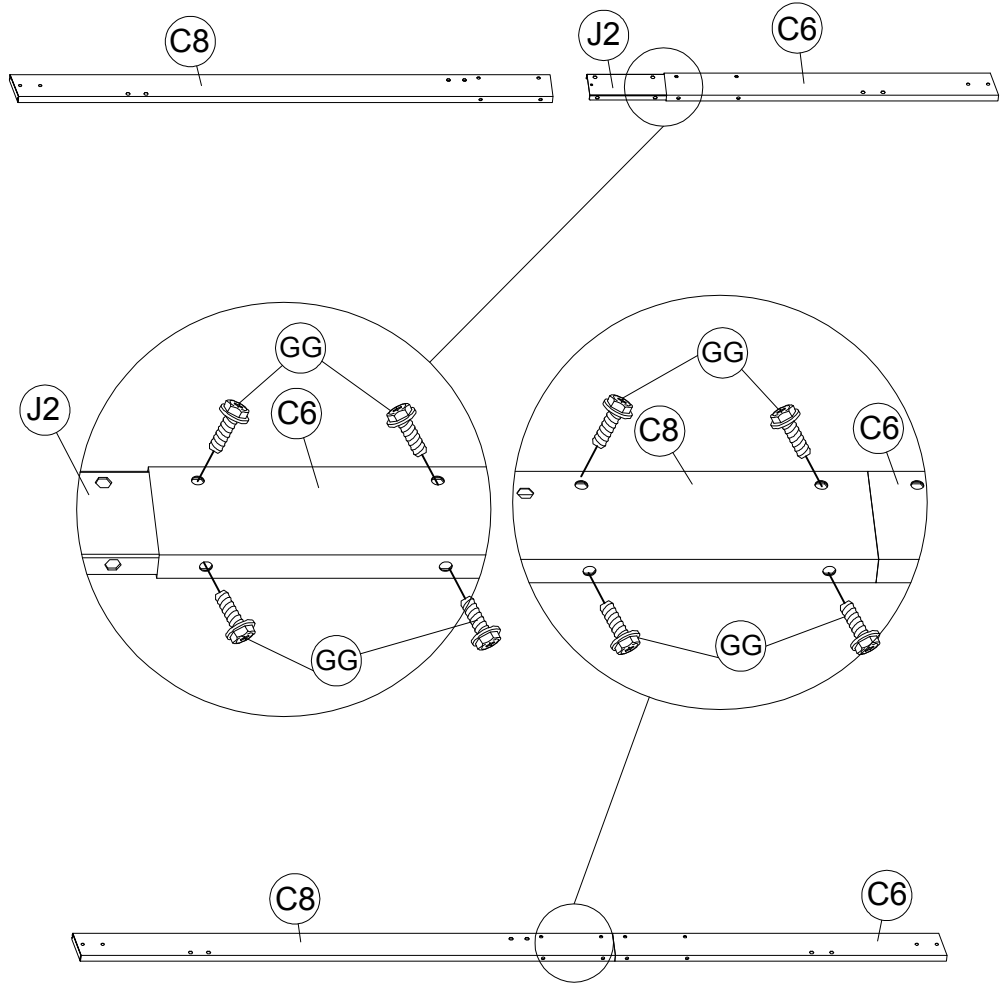

GG 8x

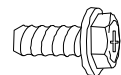

M6x15

7

EN Please note that the holes are located on the inside of the gazebo.
FR Veuillez noter que les trous sont situés à l'intérieur du gazebo.
ES Tenga en cuenta que los agujeros se encuentran en el interior del cenador.
PT Tenha em atenção que os orifícios estão situados no interior do gazebo.
DE Bitte beachten Sie, dass sich die Löcher auf der Innenseite des Pavillons befinden.
IT Si noti che i fori si trovano all'interno del gazebo.

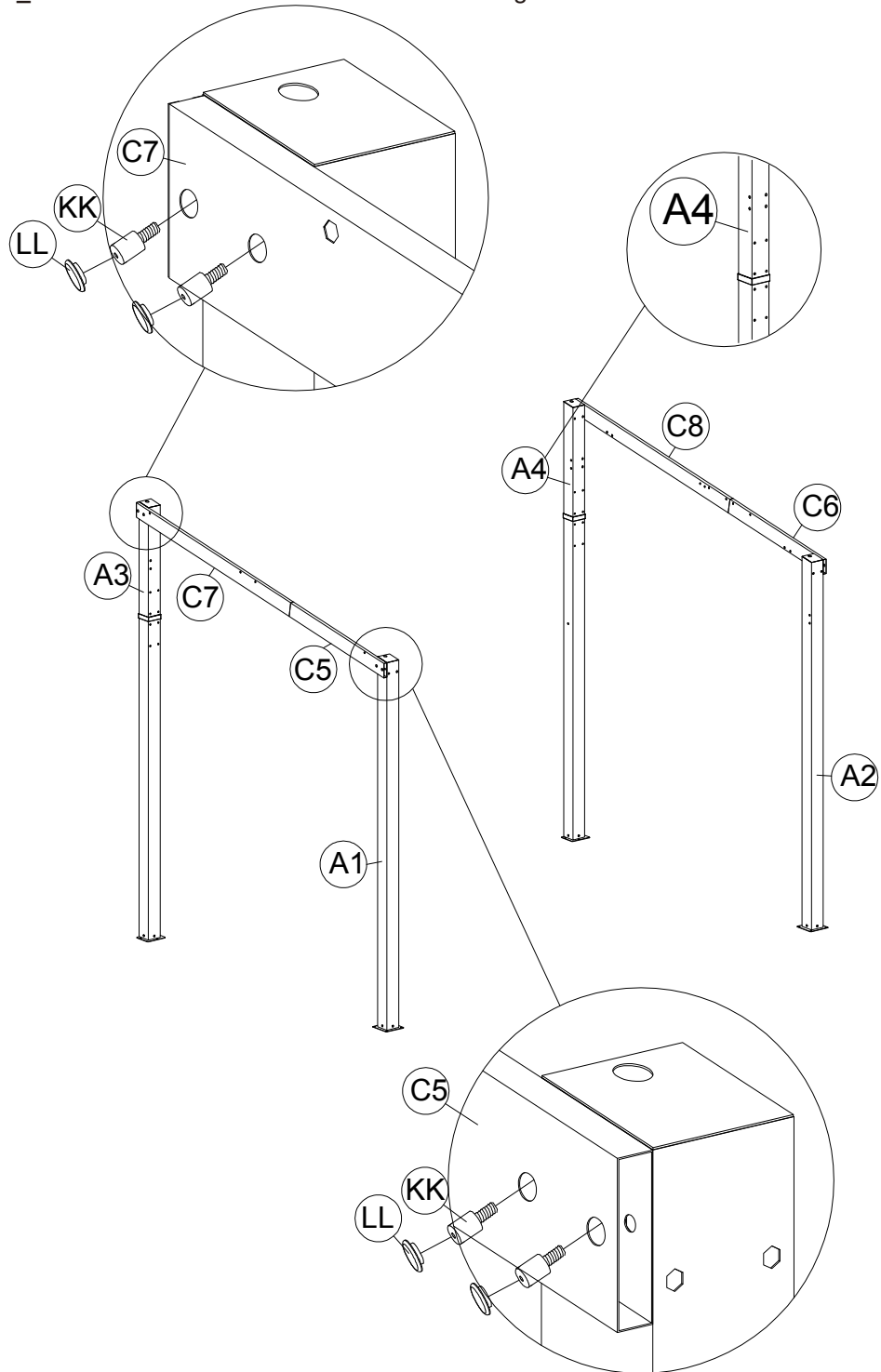

LL 8x



M6

KK 8x

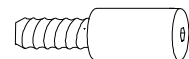

M6x35

8

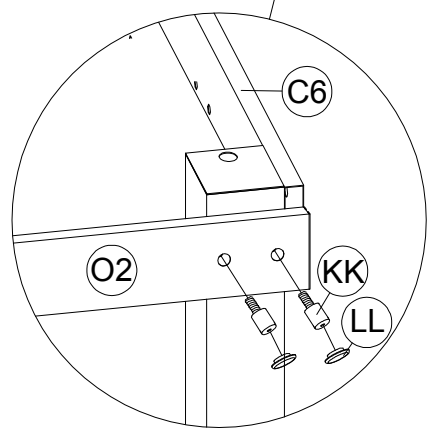
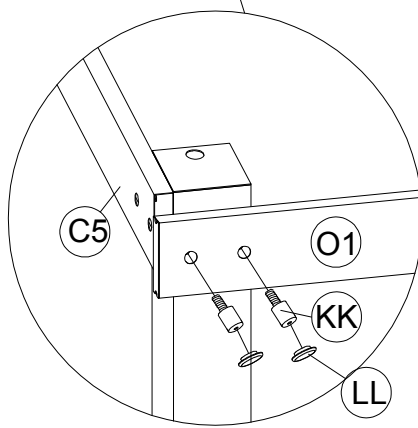
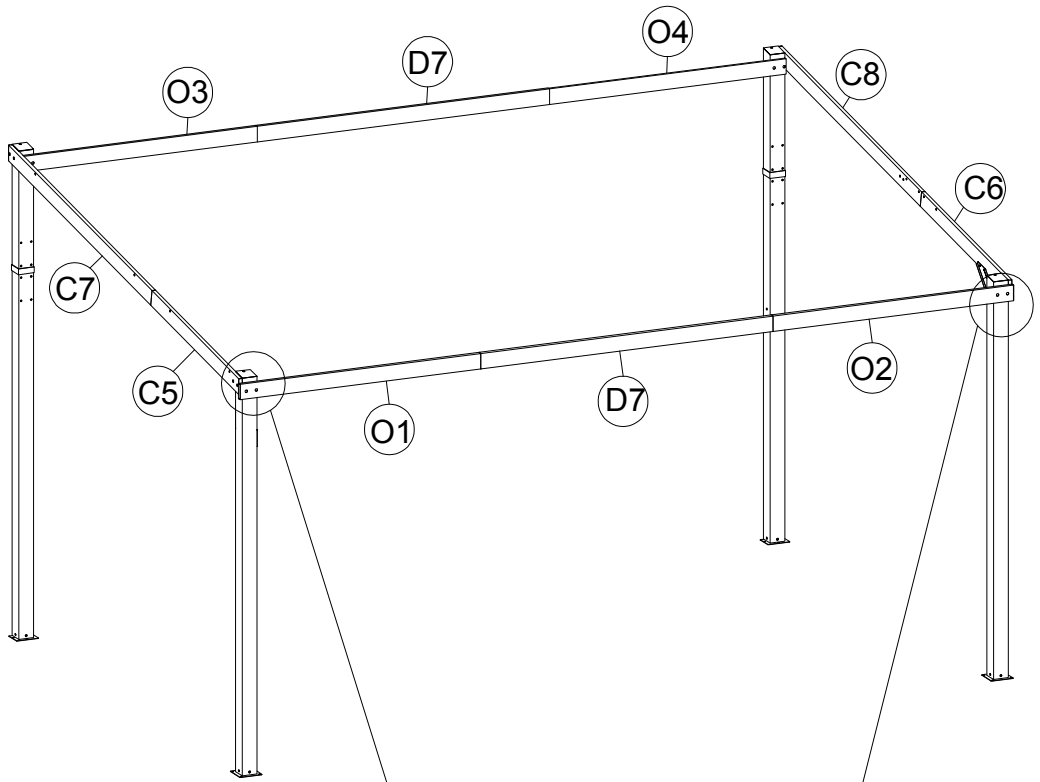

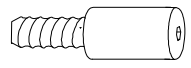
<p>LL 8x</p>  <p>M6</p>	<p>KK 8x</p>  <p>M6x35</p>
---	---

9

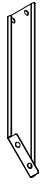

H1 2x

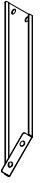

H2 2x



H3 1x



H4 1x



H5 1x



H6 1x

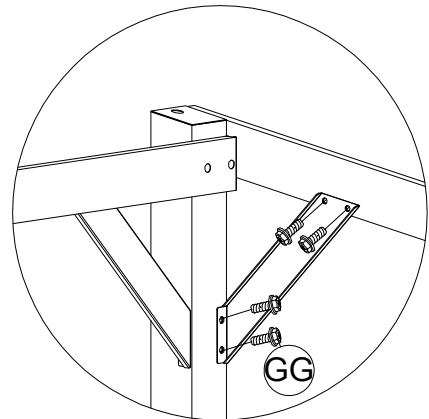
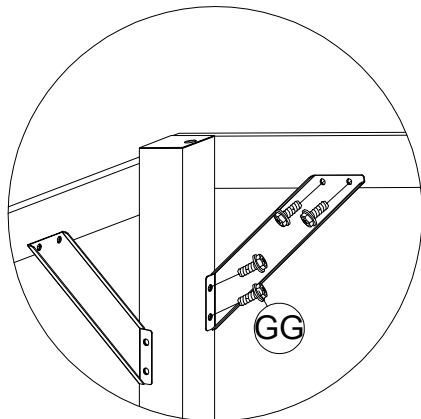
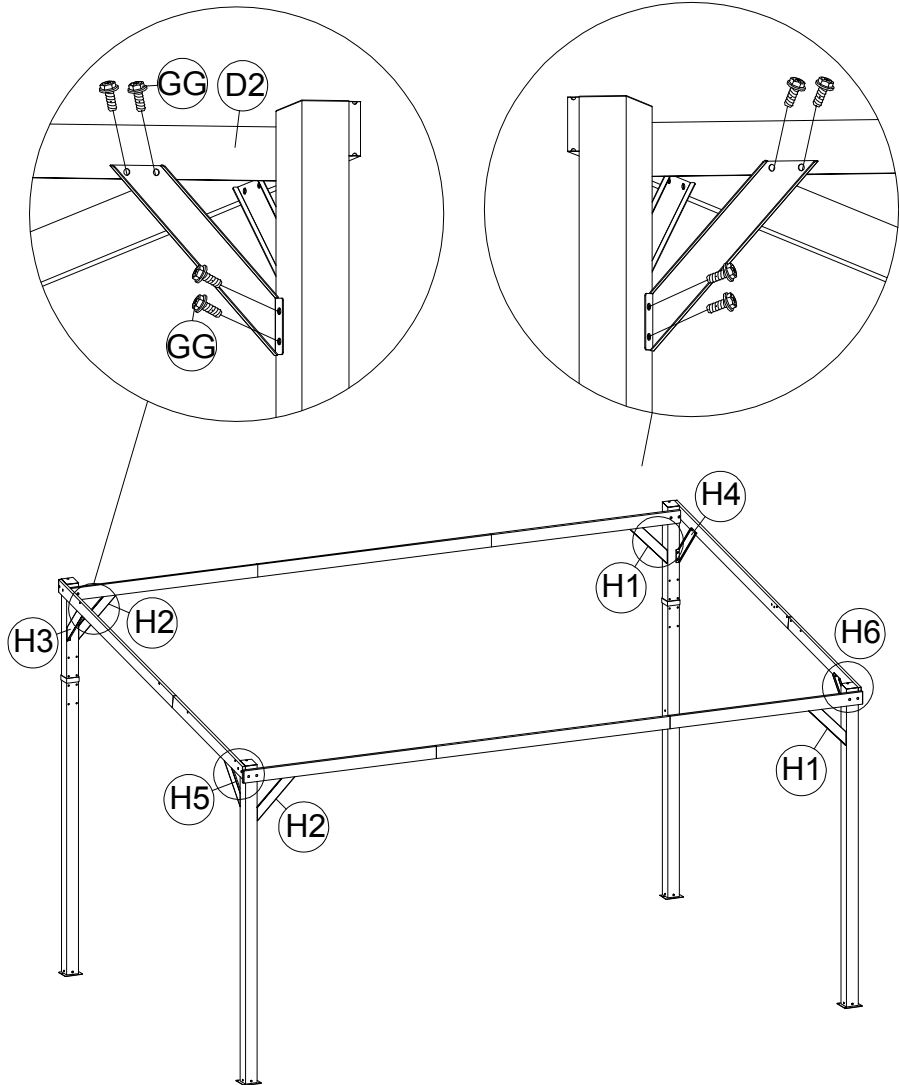

GG 32x

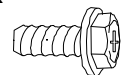

M6x15

10



(S) 14x

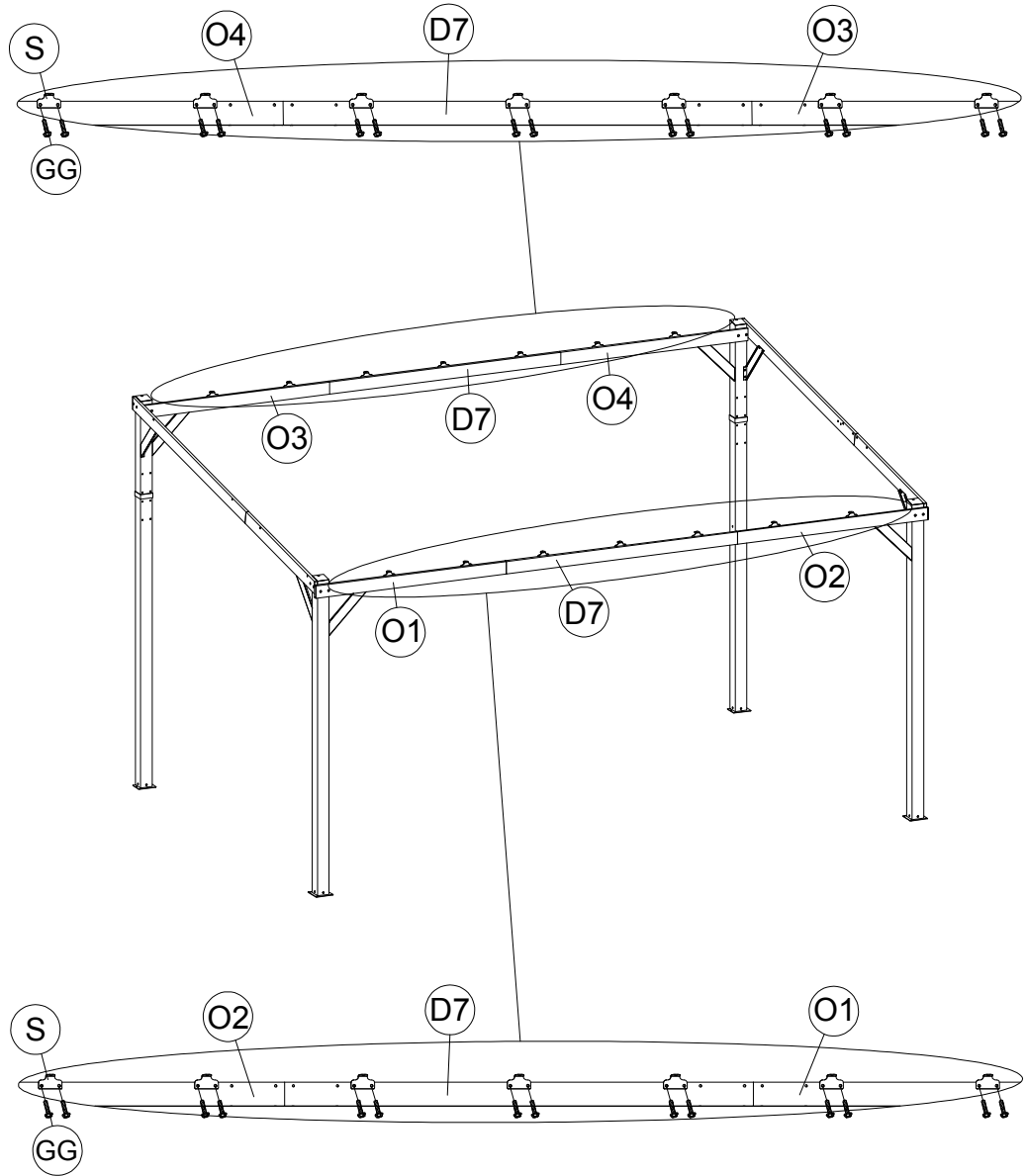

(GG) 28x

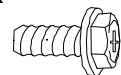

M6x15

11



W8 1x



J5 2x



W9 1x



W7 1x

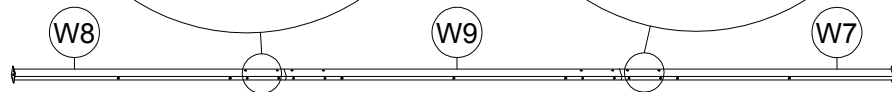
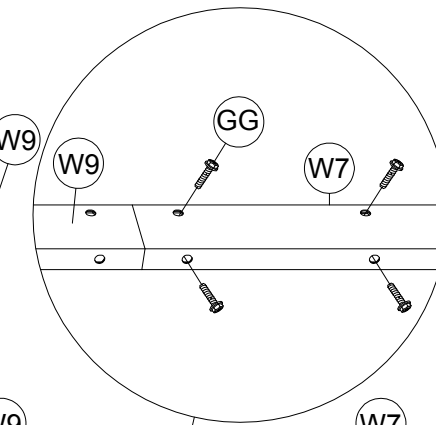
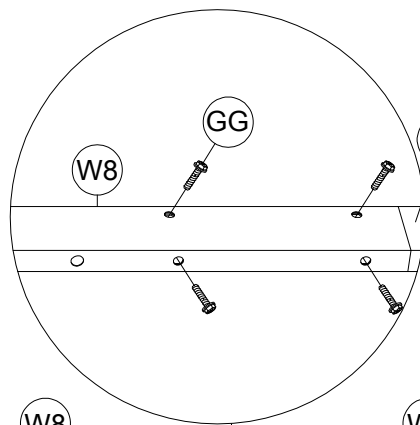
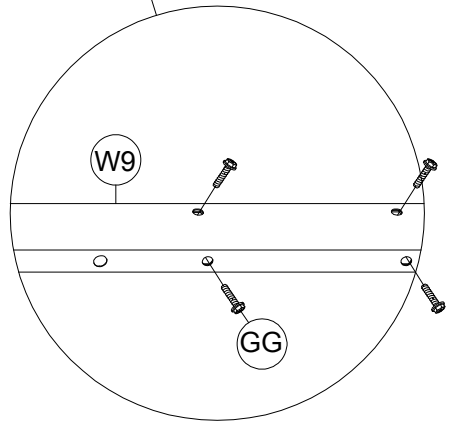
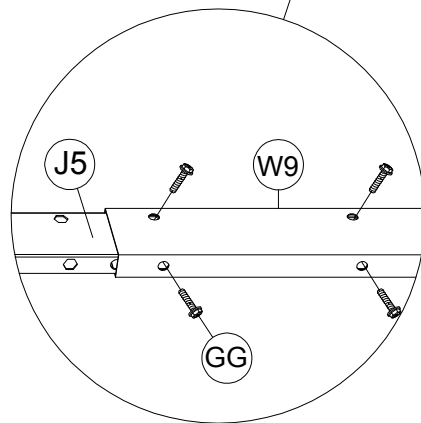
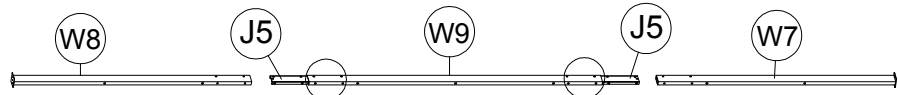

GG 16x

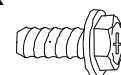

M6x15

12

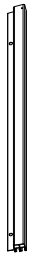

W4 1x

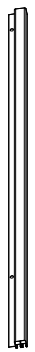

W6 1x



W3 1x



W5 1x

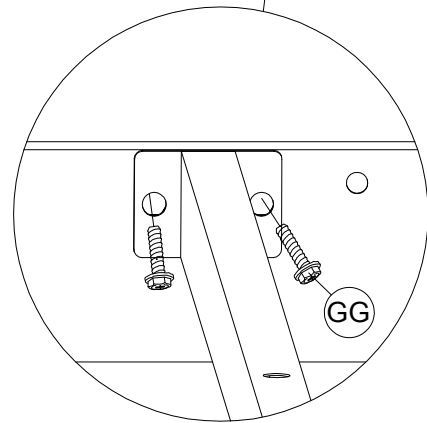
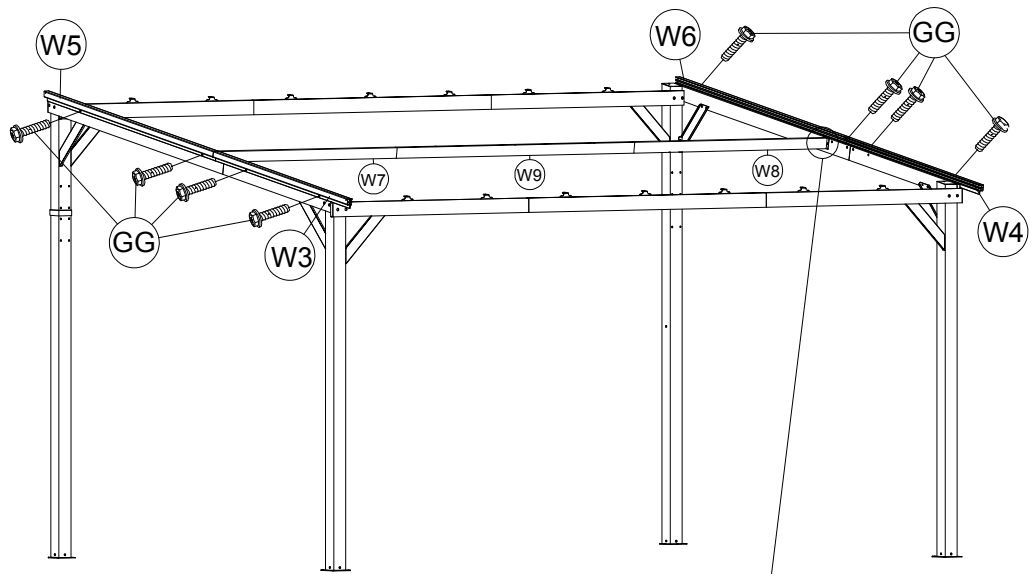

GG 12x

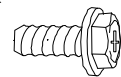

M6x15

13



E5 7x



E6 7x



J3 14x

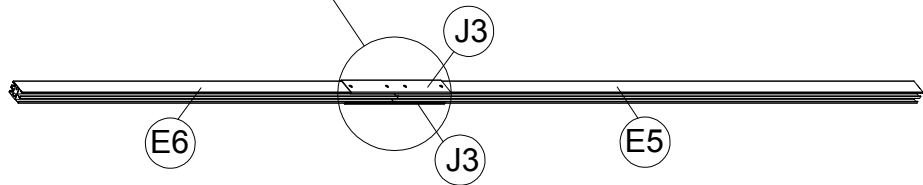
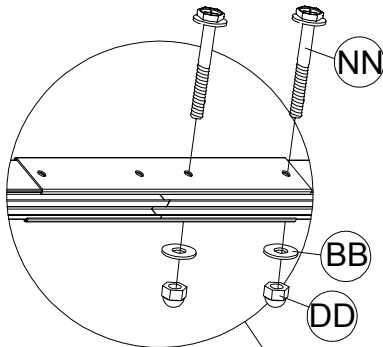
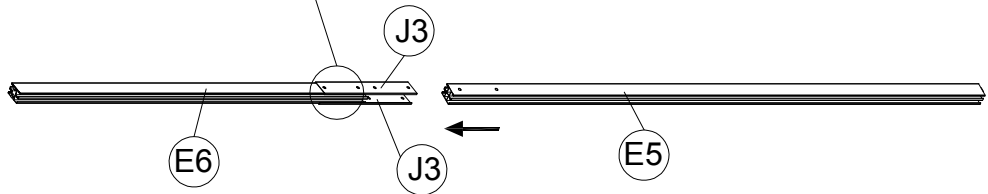
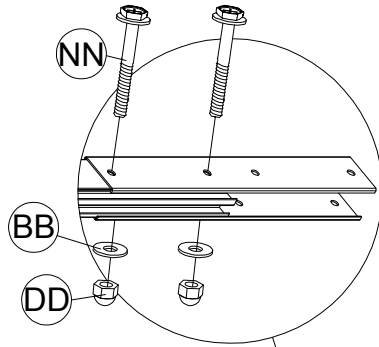
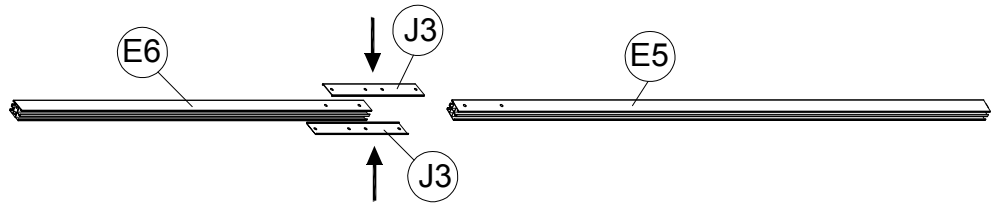

DD 28x



M6

BB 28x



M6

NN 28x

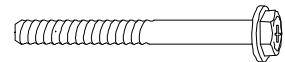

M6x50

14

EN_ Please pay attention to the position of E5 and E6 when installing, E6 is on the higher side of the inclined roof.
FR_ Veuillez faire attention à la position de E5 et E6 lors de l'installation, E6 se trouve sur le côté le plus élevé du toit incliné.
ES_ Por favor, preste atención a la posición de E5 y E6 al instalar, E6 está en el lado más alto del techo inclinado.
PT_ Ao instalar, preste atenção à posição de E5 e E6, pois E6 fica no lado mais alto do telhado inclinado.
DE_ Achten Sie bei der Installation auf die Position von E5 und E6. E6 befindet sich auf der höheren Seite des geneigten Daches.
IT_ Durante l'installazione, prestare attenzione alla posizione di E5 ed E6, in quanto E6 si trova sul lato più alto del tetto inclinato.

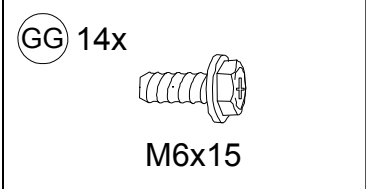
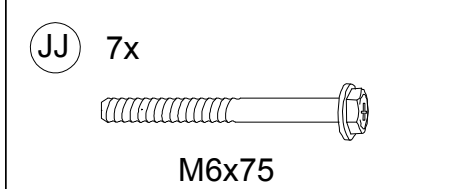
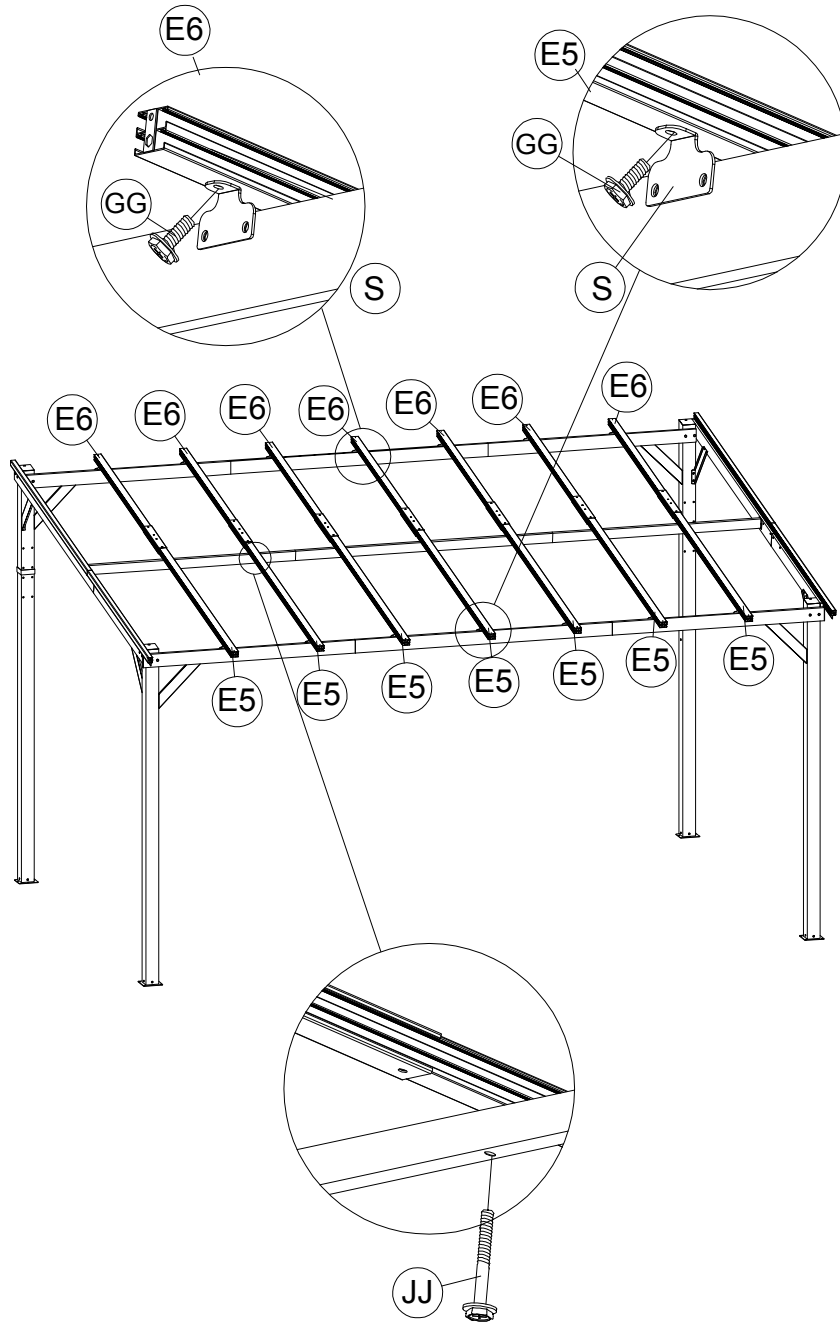

15

EN_ Use L4 to connect the two Q1's together, and when the connection is complete, you will find that one side is high and the other is low.

When pushing Q1 into the frame of the gazebo, please pay attention to the direction, starting from the high side, which is more conducive to the slide of rain .

FR_ Utilisez L4 pour connecter les deux Q1 ensemble, et lorsque la connexion est terminée, vous constaterez qu'un côté est haut et l'autre bas.

Lorsque vous poussez Q1 dans le cadre de la gloriète, faites attention à la direction, en commençant par le côté haut, qui est plus propice au glissement de la pluie.

ES_ Utilice L4 para conectar los dos Q1 juntos, y cuando la conexión esté completa, verá que un lado es alto y el otro es bajo.

Al empujar Q1 en el marco de la glorieta, por favor, preste atención a la dirección, a partir de la parte alta, que es más propicio para el deslizamiento de la lluvia .

PT_ Utilizar L4 para ligar os dois Q1 e, quando a ligação estiver concluída, verificar-se-á que um lado é alto e o outro é baixo.

Ao empurrar o Q1 para dentro da estrutura do gazebo, preste atenção à direção, começando pelo lado alto, que é mais propicio ao deslizamento da chuva.

DE_ Verwenden Sie L4, um die beiden Q1 miteinander zu verbinden, und wenn die Verbindung hergestellt ist, werden Sie feststellen, dass eine Seite hoch und die andere niedrig ist.

Wenn Sie Q1 in den Rahmen des Pavillons schieben, achten Sie bitte auf die Richtung, beginnend mit der hohen Seite, die das Abrutschen von Regen begünstigt.

IT_ Con L4 si collegano i due Q1 e, una volta completato il collegamento, si noterà che un lato è alto e l'altro è basso.

Quando si inserisce il Q1 nel telaio del gazebo, prestare attenzione alla direzione, partendo dal lato alto, che favorisce maggiormente lo scorrimento della pioggia.

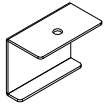

(P5) 7x



(P4) 2x

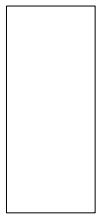

(Q1) 16x



(L4) 8x



(L3) 8x

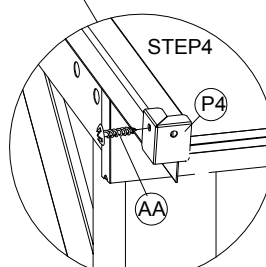
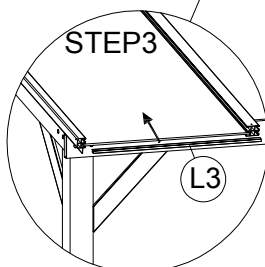
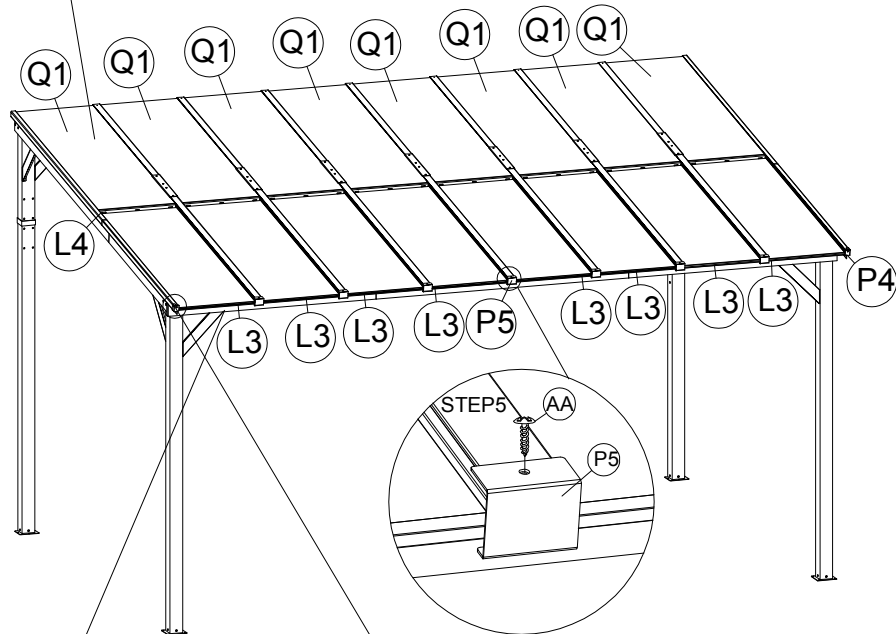
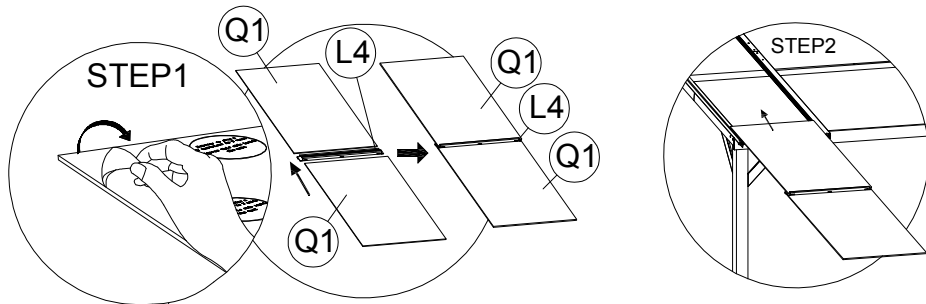

(AA) 9x



M4x16

16



P1 1x



P2 1x

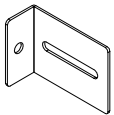

V 2x



L3 8x

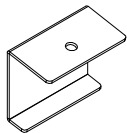

P6 7x

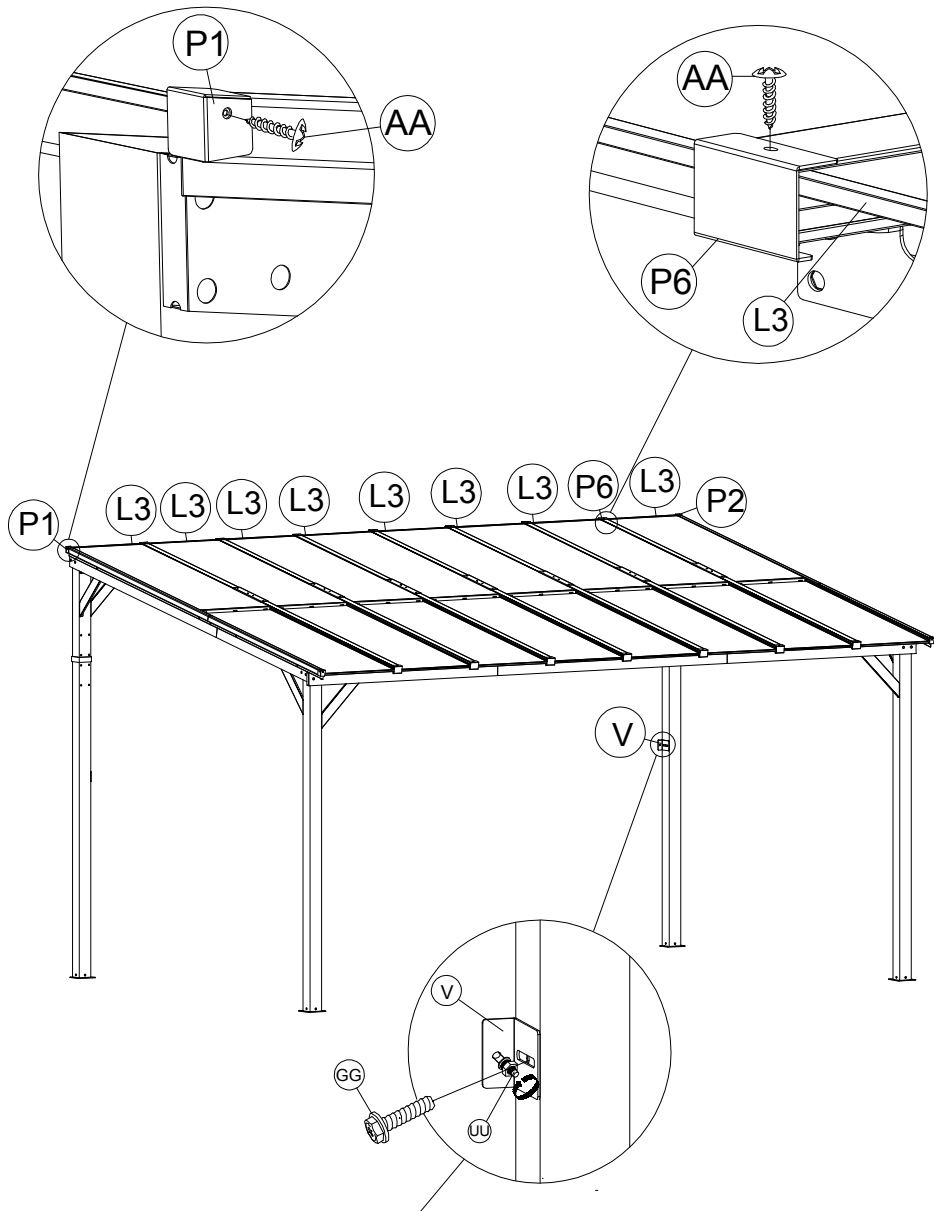

EN_ Using part V can securely fix the gazebo to the wall, allowing you to install it according to your needs.

FR_ La partie V permet de fixer solidement le gazebo au mur, ce qui vous permet de l'installer selon vos besoins.

ES_ Con la pieza V puede fijar firmemente el cenador a la pared, lo que le permite instalarlo según sus necesidades.

PT_ A utilização da peça V permite fixar firmemente a tenda à parede, permitindo-lhe instalá-la de acordo com as suas necessidades.

DE_ Mit dem Teil V können Sie den Pavillon sicher an der Wand befestigen und ihn so nach Ihren Wünschen installieren.

IT_ Utilizzando la parte V è possibile fissare saldamente il gazebo alla parete, consentendo di installarlo secondo le proprie esigenze.

AA 9x



M4x16

UU 2x

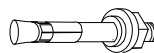

M6x80

GG 2x

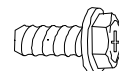

M6x15

17

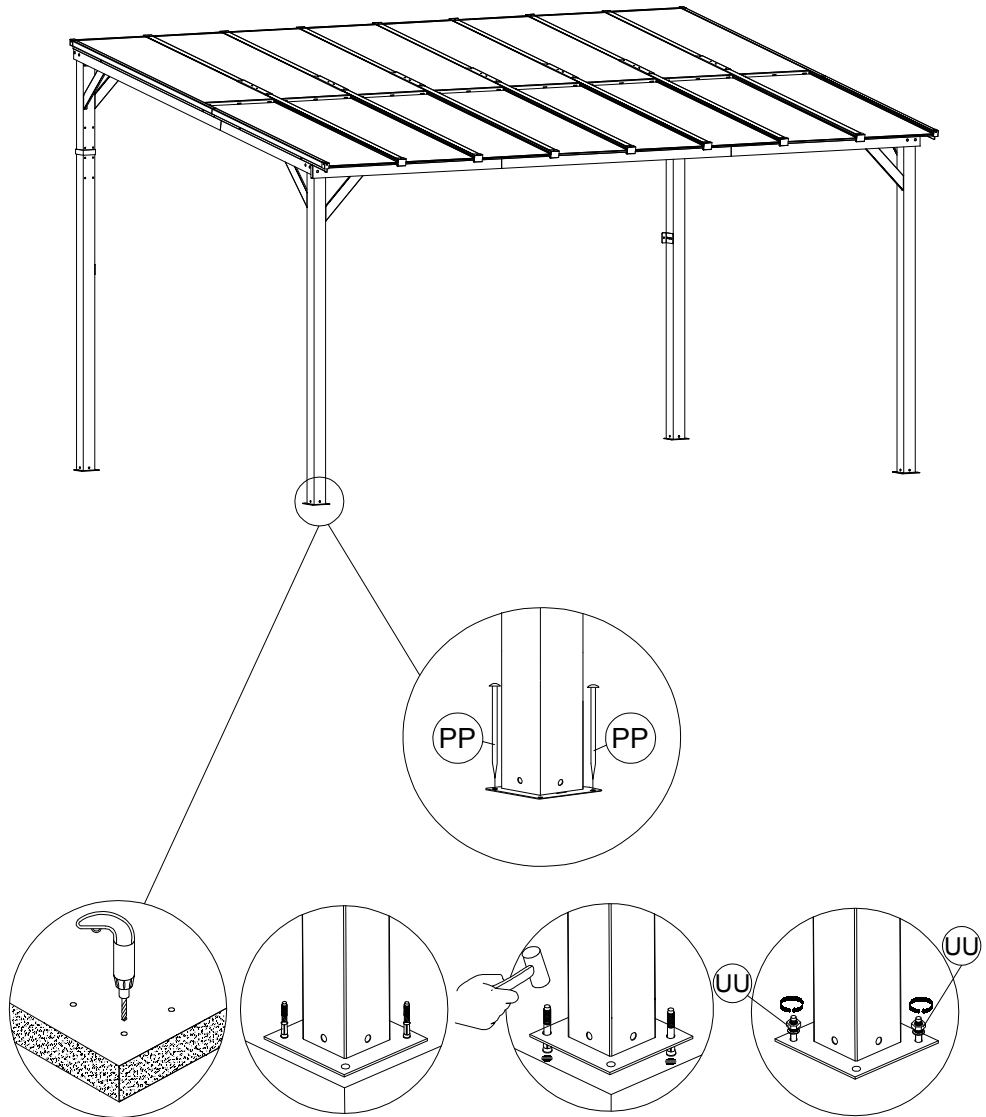

PP 8x

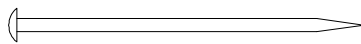

D8X180

UU 8x

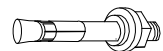

M6x80

If you have any questions, please contact our customer care center, Our contact details are below:

US

 001-877-644-9366

 customerservice@aosom.com

Imported by Aosom LLC
27150 SW Kinsman Rd Wilsonville, OR 97070 USA
MADE IN CHINA

If you have any questions, please contact our customer care center, Our contact details are below:

CA

 416-792-6088

 customerservice@aosom.ca

Imported by Aosom Canada Inc.
7270 Woodbine Avenue, Unit 307, Markham,
Ontario Canada L3R 4B9
MADE IN CHINA

Si vous avez la moindre question, veuillez contacter notre centre d'assistance à la clientèle, Nos coordonnées sont les suivantes:

 416-792-6088

 customerservice@aosom.ca

Importé par Aosom Canada Inc.
7270 Woodbine Avenue, unité 307,
Markham, Ontario Canada L3R 4B9
FABRIQUÉ EN CHINE

If you have any questions, please contact our customer care center, Our contact details are below:

UK

 0044-800-240-4004

 enquiries@mhstar.co.uk

IMPORTER ADDRESS:
MH STAR UK LTD
Unit 27, Perivale Park,
Horsenden lane South
Perivale, UB6 7RH
MADE IN CHINA

Si vous avez la moindre question, veuillez contacter notre centre d'assistance à la clientèle, Nos coordonnées sont les suivantes:

FR

 0033-1-84166106

 aosom@mhfrance.fr

Importé par/Fabricant/REP:
MH FRANCE
2 Rue Maurice Hartmann
92130 Issy Les Moulineaux
France
FABRIQUÉ EN CHINE

Wenn Sie Fragen haben, wenden Sie sich bitte an unser Kundendienstzentrum, Unsere Kontaktdaten stehen unten:

DE

 0049-0(40)-87408465

 service@aosom.de

ADRESSE DES IMPORTEURE/Hersteller/REP:
MH Handel GmbH
Wendenstraße 309
D-20537 Hamburg
Germany
IN CHINA HERGESTELLT

In caso di dubbio, si prega di contattare il nostro centro assistenza clienti, I nostri dettagli di contatto sono di seguito:

IT

 0039-0249471447

 clienti@aosom.it

IMPORTATO DA/Produttore/REP:
AOSOM Italy srl
Centro Direzionale Milanofiori
Strada 1 Palazzo F1
20057 Assago (MI)
P.I.: 08567220960
FATTO IN CINA

Si tiene alguna pregunta, comuníquese con nuestro Centro de Atención al Cliente, Nuestros datos de contacto son los siguientes:

ES

 0034-931294512

 atencioncliente@aosom.es

IMPORTADOR/Fabricante/REP:
SPANISH AOSOM, S.L.
C/ROC GROS, N°15.08550, ELS HOSTALETES DE
BALENYÀ, SPAIN.
B66295775
HECHO EN CHINA

Se tiver alguma dúvida, por favor contacte o nosso Centro de Atendimento ao Cliente, Os nossos dados de contacto são os seguintes:

 0034-931294512

 info@aosom.pt.

IMPORTADOR/Fabricante/REP:
SPANISH AOSOM, S.L.
C.ROC GROS N.15, 08550. ELS HOSTALETES DE
BALENYÀ
FEITO NA CHINA



FR

**DONNEZ
OU
RECYCLEZ**



ASSOCIATION

OU



LIVRAISON

OU



DÉCHÈTERIE

Adresses sur quefairedemesdechets.fr