

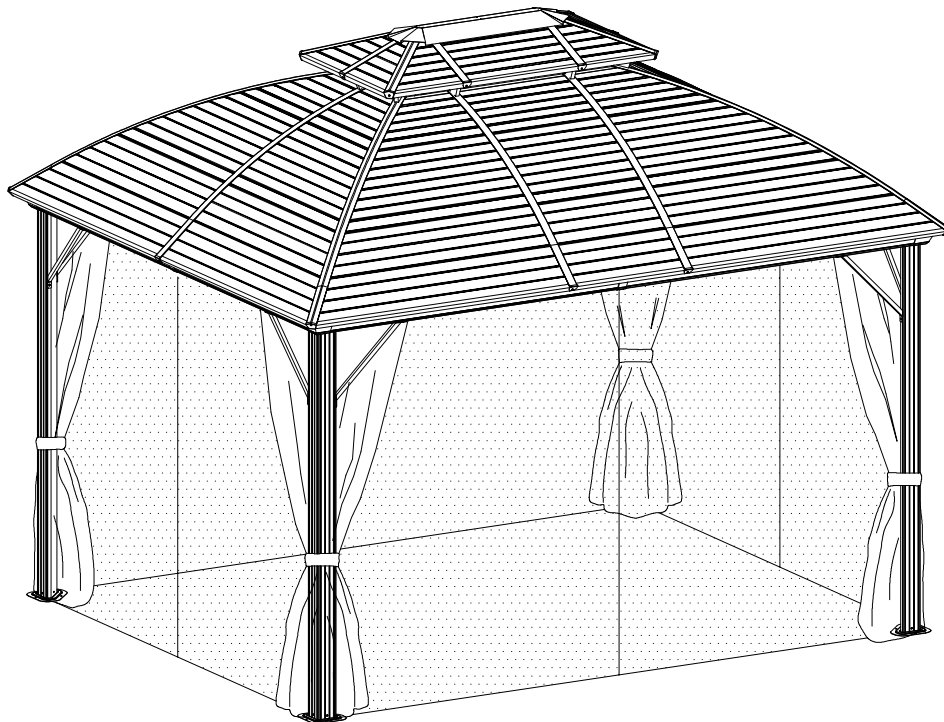

IN240900311V01_GL

84C-205V01



21
STEPS

3 HR

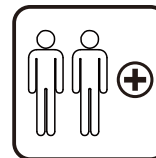
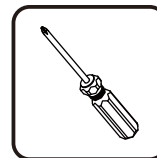
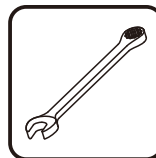
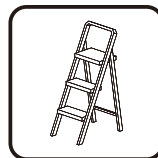
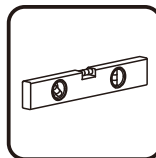
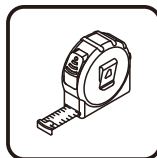
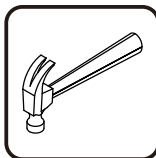
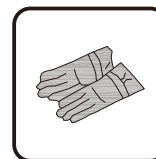
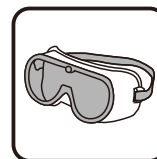
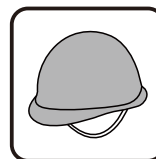

Tools Recommended

EN_IMPORTANT, RETAIN FOR FUTURE REFERENCE: READ CAREFULLY.

FR_IMPORTANT: A LIRE ATTENTIVEMENT ET À CONSERVER POUR CONSULTATION ULTÉRIEURE.

ES_IMPORTANTE, LEA Y GUARDE PARA FUTURAS REFERENCIAS.

PT_IMPORTANTE, RETER PARA REFERÊNCIA FUTURA: LEIA ATENTAMENTE.

DE_WICHTIG! SORFGFÄLTIG LESEN UND FÜR SPÄTERES NACHSCHLAGEN AUFBEWAHREN.

IT_IMPORTANTE! CONSERVARE IL PRESENTE MANUALE PER FUTURO RIFERIMENTO E LEGGERLO ATTENTAMENTE.

EN**IMPORTANT SAFETY NOTICE**

Product is NOT INTENDED for the following:

- A safety barrier to prevent unsupervised access to pools, hot tubs, spas or ponds.
- As load bearing support for a building, structure, heavy objects or swings.
- Used in structures that trap wind, rain or snow that would create extra load on the product.

Accumulated snow must be removed from roof.

DO NOT climb or walk on roof for any reason.

Wear gloves to avoid injury from possible sharp edges of individual elements before assembly.

During installation, follow all safety warnings provided with your tools.

Some structures may require two or more people to install safely.

Check for underground utilities before digging or driving stakes into the ground!

It is important during assembly to closely follow the instructions, complete the assembly on a solid level surface and that you follow the instruction to square up, level and anchor the structure, this will reduce the gap at connections during assembly.

FR**AVIS IMPORTANT DE SÉCURITÉ**

Le produit n'est PAS DESTINÉ à ce qui suit :

- Une barrière de sécurité pour empêcher l'accès non surveillé aux piscines, aux spas, aux cuves thermales ou aux étangs.
- Comme support de charge pour un bâtiment, une structure, des objets lourds ou des balançoires.
- Utilisé dans des structures qui retiennent le vent, la pluie ou la neige qui créeraient une charge supplémentaire sur le produit.

La neige accumulée doit être enlevée du toit.

NE PAS grimper ou marcher sur le toit pour quelque raison que ce soit.

Portez des gants pour éviter les blessures causées par d'éventuels bords tranchants des composants avant de procéder à l'assemblage.

Lors de l'installation, respectez tous les avertissements de sécurité fournis avec vos outils.

Certaines structures peuvent nécessiter l'intervention de deux personnes ou plus pour les installer en toute sécurité.

Vérifiez la présence de services publics souterrains avant de creuser ou de planter des piquets dans le sol !

Il est important, pendant tout le processus de montage, de suivre attentivement les instructions, de terminer l'assemblage sur une surface solide et plane et de suivre les instructions d'équerrage, de mise à niveau et d'ancrage de la structure, ce qui permettra de réduire les écarts au niveau des liaisons pendant le montage.

ES**AVISO IMPORTANTE DE SEGURIDAD**

Manténgase alejado de las líneas eléctricas aéreas.

No coloque ni instale su tienda de campaña debajo de los árboles debido a posibles rayos o hundimiento de las ramas de los árboles en condiciones climáticas adversas. Para obtener las mejores condiciones en caso de viento fuerte, coloque el extremo estrecho de la tienda en la dirección del viento.

No dejes caer la tienda de campaña.

No haga rebotar ni golpee la bolsa de la tienda para sacarla, estas acciones podrían dañar el marco.

ESTE PRODUCTO REQUIERE UN MÍNIMO DE DOS PERSONAS PARA SU MONTAJE

Bajo ninguna circunstancia se debe utilizar este producto para cubrir automóviles, vehículos marinos o artículos similares.

PRECAUCIÓN: Vigile no pellizcarse los dedos durante el montaje y desmontaje de la tienda al unir las piezas del marco.

PT**AVISO DE SEGURANÇA IMPORTANTE**

O produto NÃO é DESTINADO ao seguinte:

- Uma barreira de segurança para impedir o acesso sem supervisão a piscinas, banheiras, spas ou lagos.
- Como suporte de carga para um edifício, estrutura, objectos pesados ou baloiços.
- Usado em estruturas que apanham vento, chuva ou neve que criariam carga extra sobre o produto.

A neve acumulada deve ser removida do telhado. NÃO subir ou caminhar no telhado por qualquer razão.

Usar luvas para evitar ferimentos causados por possíveis arestas vivas de elementos individuais antes da montagem.

Durante a instalação, siga todos os avisos de segurança fornecidos com as suas ferramentas. Algumas estruturas podem exigir a instalação segura de duas ou mais pessoas. Verifique a existência de utilidades subterrâneas antes de escavar ou de conduzir estacas no solo!

É importante durante a montagem seguir de perto as instruções, completar a montagem numa superfície sólida e nivelar e ancorar a estrutura, o que reduzirá a folga nas ligações durante a montagem.

DE**WICHTIGER SICHERHEITSHINWEIS**

Das Produkt ist NICHT für einen der folgenden Anwendungen bestimmt:

- Als Sicherheitsbarriere, die den unbeaufsichtigten Zugang zu Pools, Whirlpools, Spas oder Teichen verhindert.
- Als tragende Stütze für ein Gebäude, eine Struktur, schwere Gegenstände oder Schaukeln.
- Als Bestandteil einer Struktur verwendet werden, welche Wind, Regen oder Schnee abfangen, die eine zusätzliche Belastung für das Produkt darstellen würden.

Angesammelter Schnee muss vom Dach entfernt werden.

Aus keinem Grund darf das Dach bestiegen oder betreten werden.

Bitte tragen Sie stets geeignete Arbeitshandschuhe, um Verletzungen durch mögliche scharfe Kanten einzelner Elemente während der Montage zu vermeiden.

Befolgen Sie während des Installationsprozesses bitte sorgfältig alle Sicherheitswarnungen, die mit Ihren Werkzeugen geliefert werden.

Einige Strukturen können zwei oder mehr Personen erfordern, um sicher installiert zu werden.

Prüfen Sie vor dem Graben oder Eintreiben von Pfählen in den Boden, ob Erdkabel vorhanden sind!

Es ist wichtig, während der Montage die Anweisungen genau zu befolgen, Ihr Produkt auf einem festen und ebenen Untergrund aufzustellen und die Anweisung zum Aufrichten, Nivellieren und Verankern der Struktur zu befolgen, da dadurch der Spalt an den Verbindungen während der Montage verringert wird.

IT**IMPORTANTI PRECAUZIONI DI SICUREZZA**

Il prodotto NON è PROGETTATO per quanto segue:

- Una barriera di sicurezza per impedire l'accesso senza supervisione a piscine, vasche idromassaggio, spa o stagni.
- Supporto portante di edifici, strutture, oggetti pesanti o altalene.
- Parte di strutture che accumulano vento, pioggia o neve, in quanto creerebbero un carico extra sul prodotto.

La neve accumulata deve essere rimossa dal tetto.

NON salire o camminare sul tetto per nessun motivo.

Indossare guanti per evitare lesioni derivanti da spigoli vivi dei singoli componenti prima del montaggio.

Durante l'installazione, seguire tutte le precauzioni di sicurezza fornite con gli strumenti.

Alcune strutture possono richiedere due o più persone per essere installate in sicurezza.

Controlla le utenze sotterranee prima di scavare o piantare pali nel terreno!

È importante che durante il montaggio vengano seguite attentamente le istruzioni, inoltre completare il montaggio su una superficie piana e solida e seguire le istruzioni per allineare, livellare e ancorare la struttura, in quanto questo ridurrà lo spazio necessario durante il montaggio.

Carton-1/4		Carton-3/4		Carton-4/4	
Part	Qty	Part	Qty	Part	Qty
A	4	D1	4	Q	4
B	2	D2	4	Q1	4
B1	2	E	4	Q2	4
T1	4+1	F1	4	Q3	4
1.2.3.4.5	1	F2	4	Q4	4
		G3	2	R	2
		H	8	R1	4
		P	4	R2	4
Carton-2/4				S	2
Part	Qty			S1	4
C	2			S2	4
C1	2				
E1	6				
G	4				
G1	4				
G2	4				
G4	2				
H	4				
J	4				
K	4				
K1	4				
L	1				
M	1				
P1	4				
T	4				
N.N1.N2.N3.N4 U.V.Y.W.8	1				



A 4x

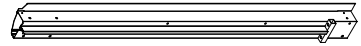

B 2x

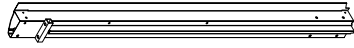

B1 2x

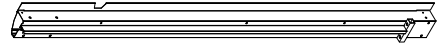

C 2x

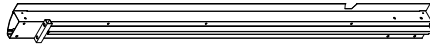

C1 2x

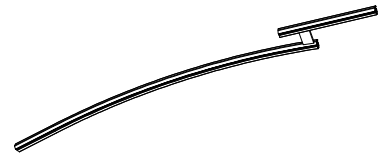

E 4x

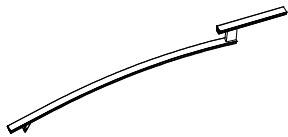

E1 6x

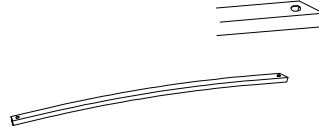

F1 4x

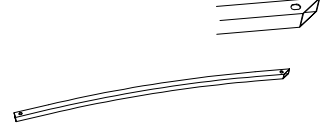

F2 4x



G 4x



G1 4x



G2 4x



G3 2x



G4 2x

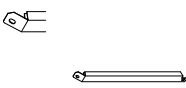

D1 4x

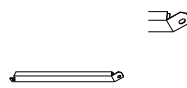

D2 4x

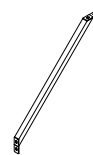

H 12x

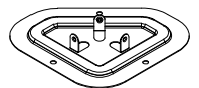

J 4x

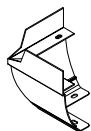

K 4x





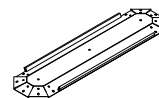



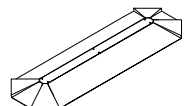









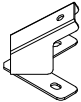
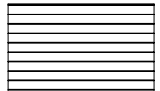
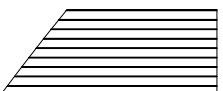
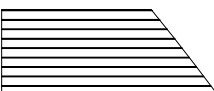
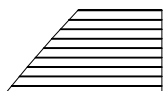
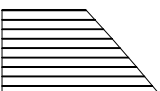
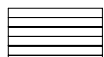

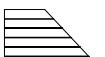
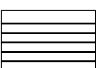

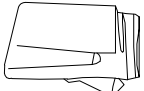
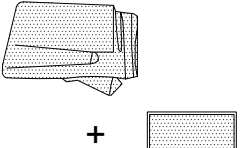

K1 4x



L 1x



M 1x

			
(N) 4x	(N1) 12x	(N2) 4x	(N3) 8x
			
(N4) 8x	(P) 4x	(P1) 4x	(Q) 4x
			
(Q1) 4x	(Q2) 4x	(Q3) 4x	(Q4) 4x
			
(R) 2x	(R1) 4x	(R2) 4x	(S) 2x
			
(S1) 4x	(S2) 4x	(T) 4x	(T1) 4x
			
(U) 104x	(V) 4x	(Y) 40x	(W) 12x
			
M6x15 (1) 183x	M6x35 (2) 16x	M5x12 (3) 4x	ST4.8x12 (4) 24x
			
(5) 2x	(8) 12x	S4 1x	

<1>



A 4x

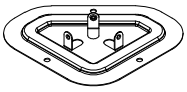

J 4x



1 12x M6x15

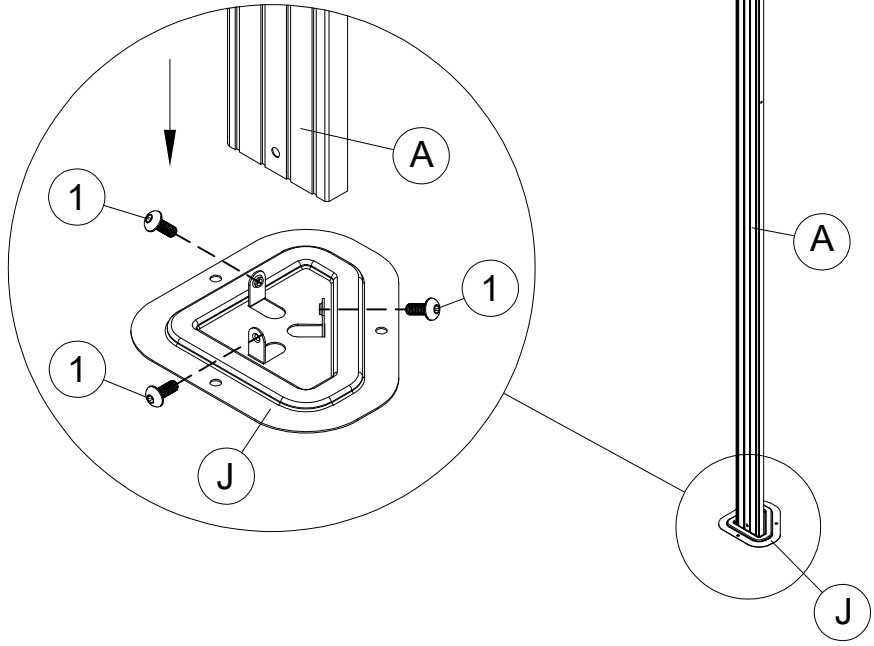

<2>

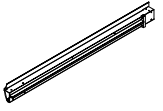

B 2x

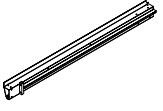

B1 2x

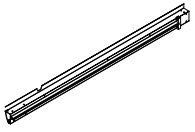

C 2x

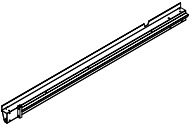

C1 2x

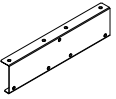

P 4x



1 34x M6x15

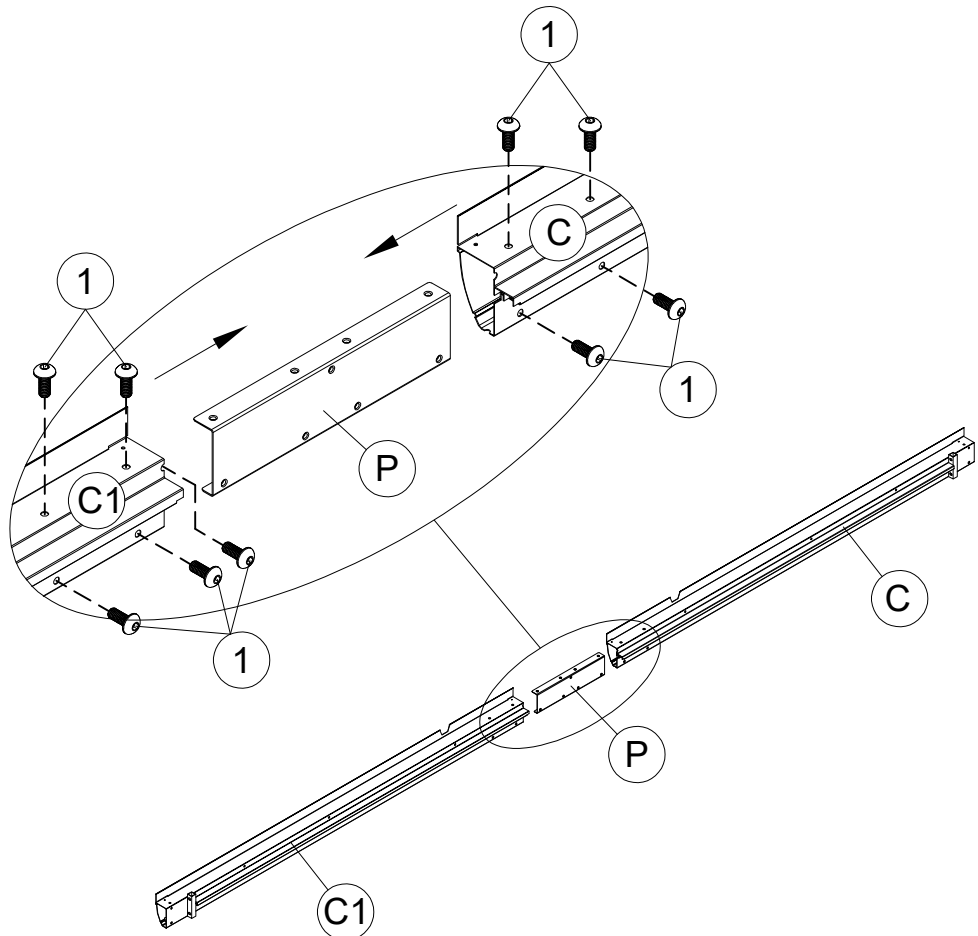
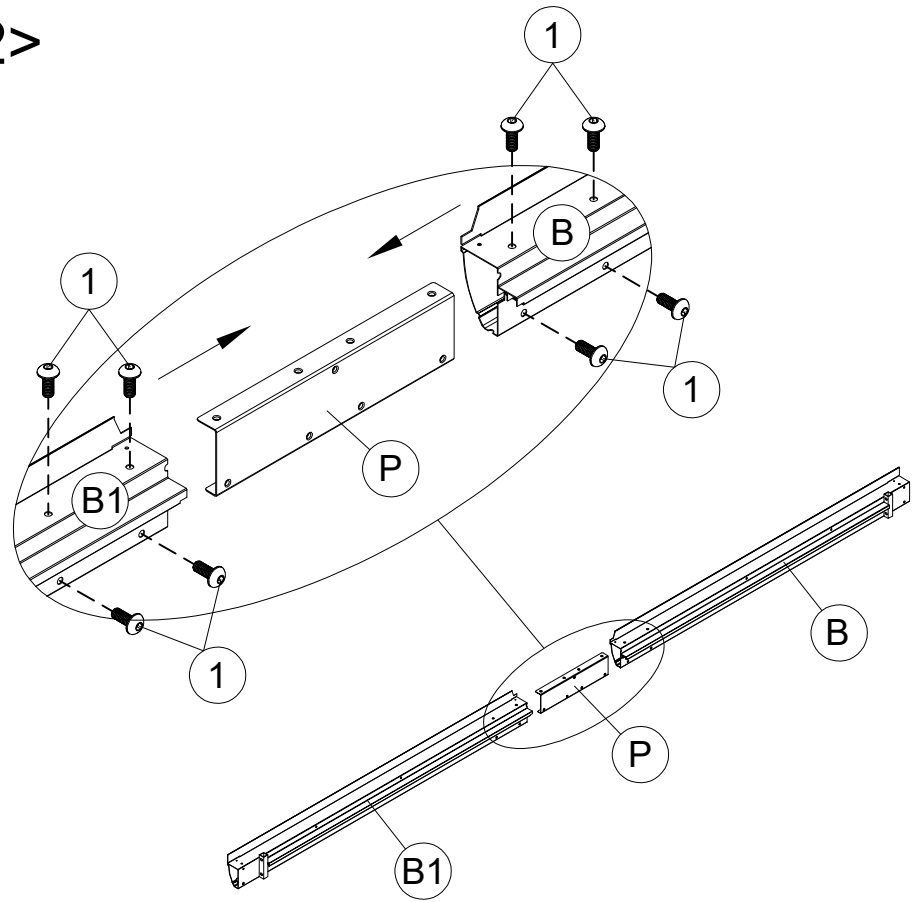

5



<3>

1 M6x15
16x



2 M6x35
16x

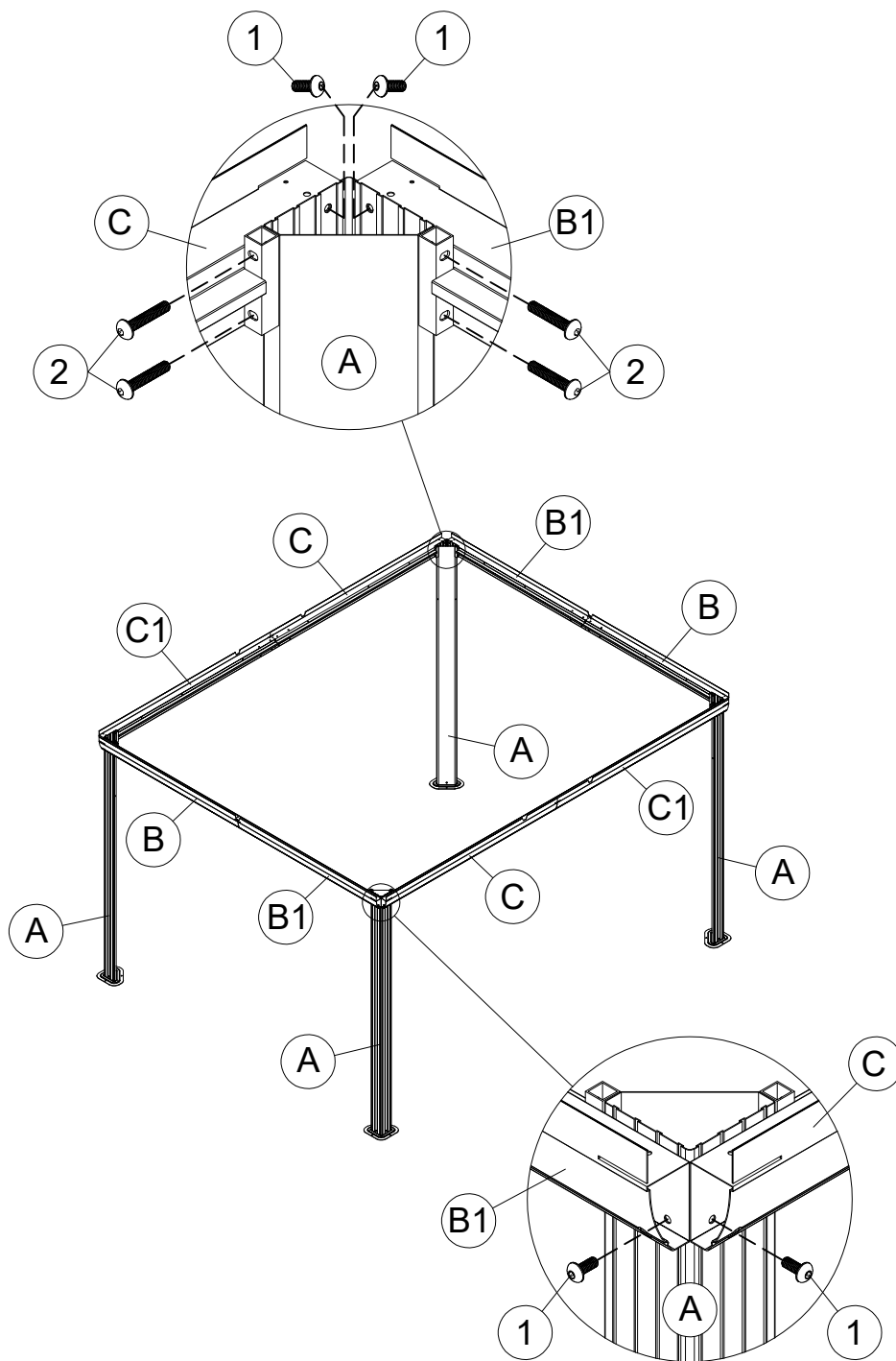

6

<4>

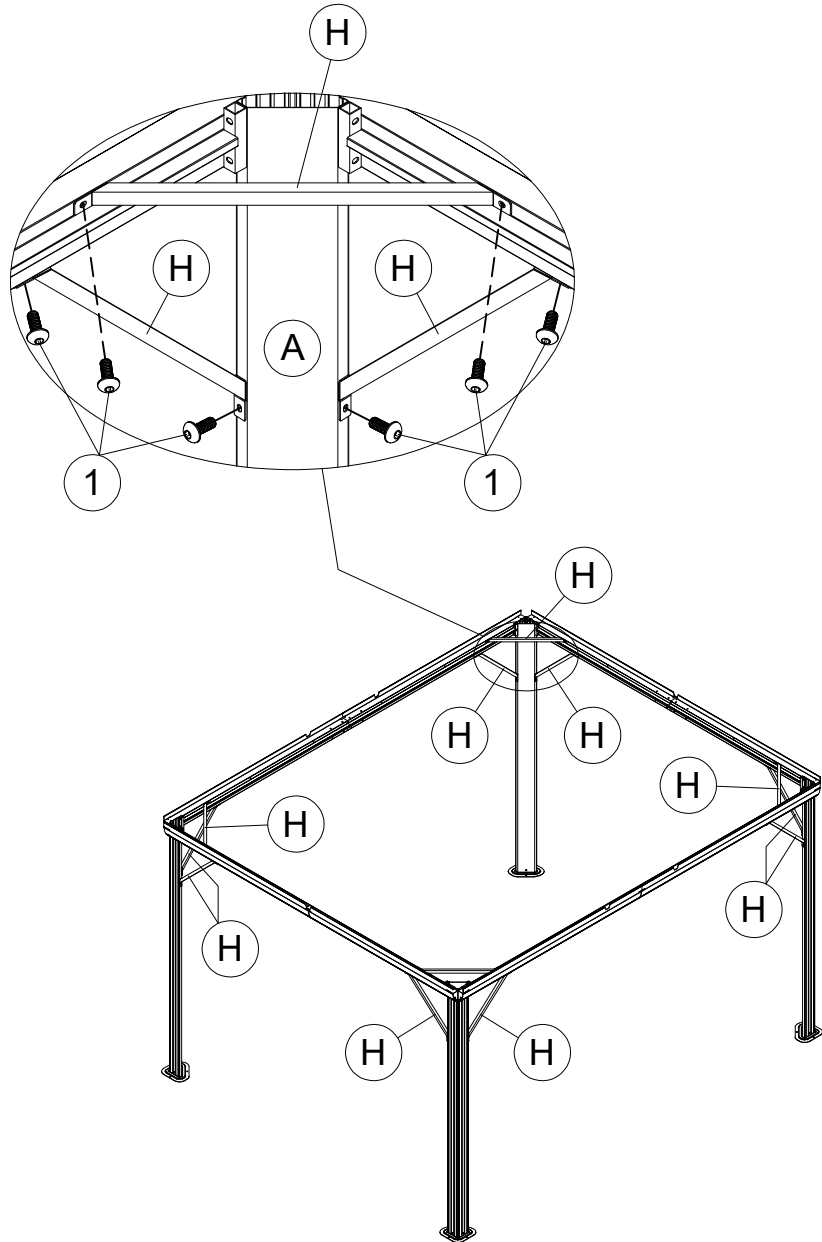
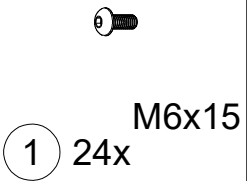
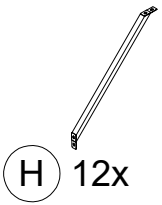

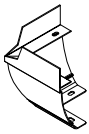

(K) 4x



(K1) 4x



(U) 104x



(V) 4x



(3) 4x M5x12



(4) 24x ST4.8x12

8

<5>

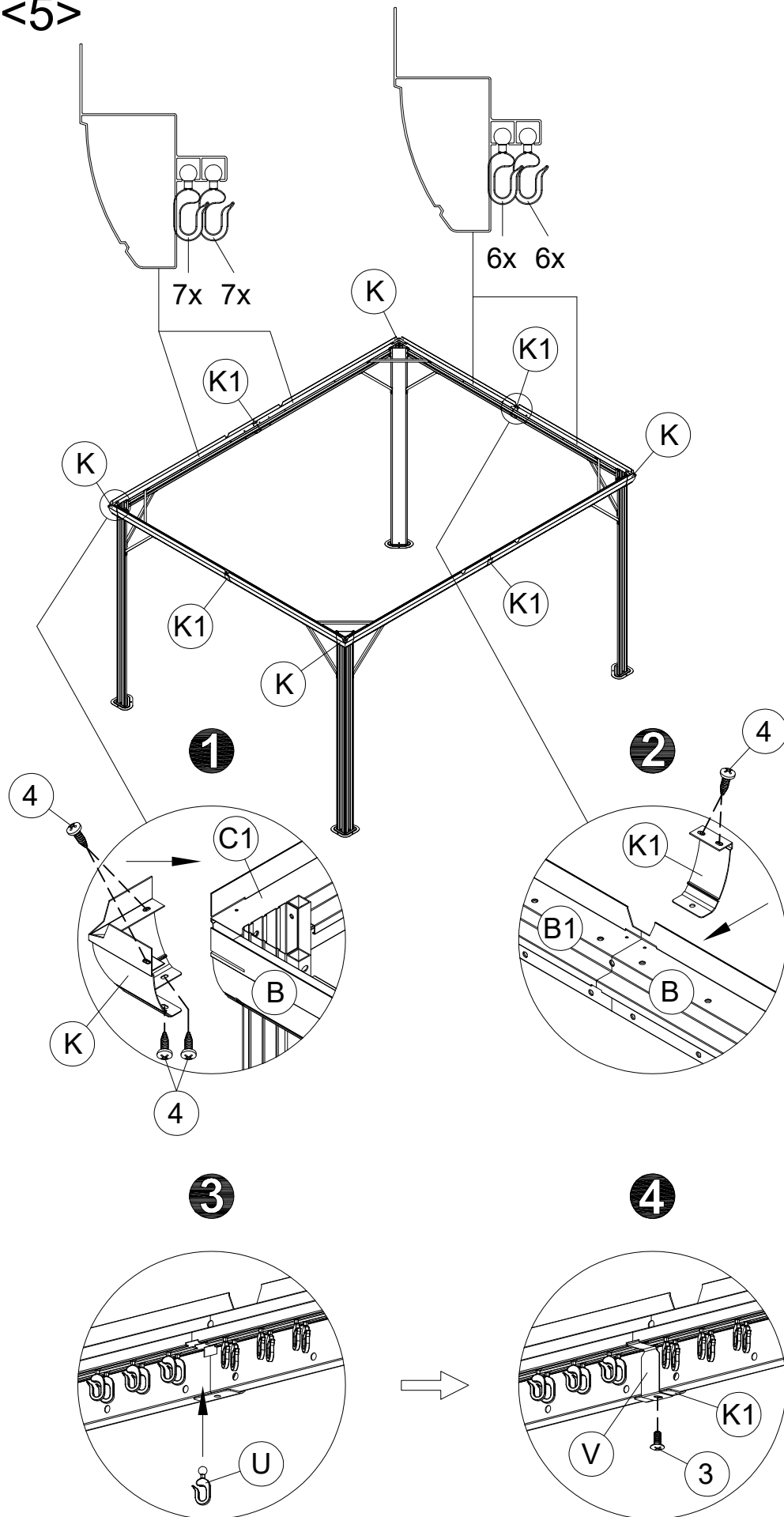

<6>



E 4x

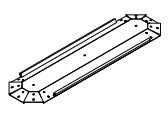

L 1x

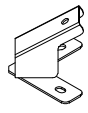

P1 4x



1 12x M6x15

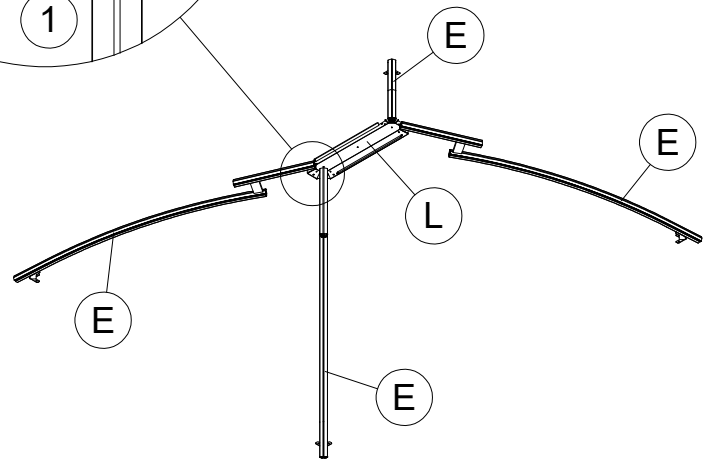
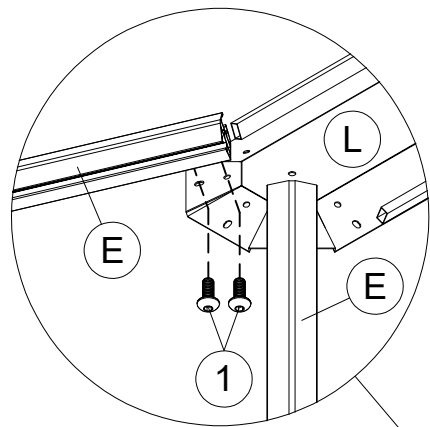
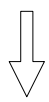
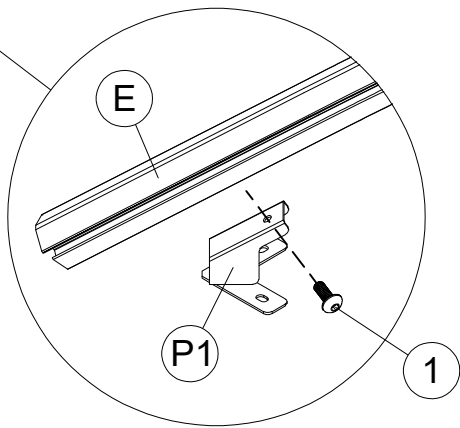
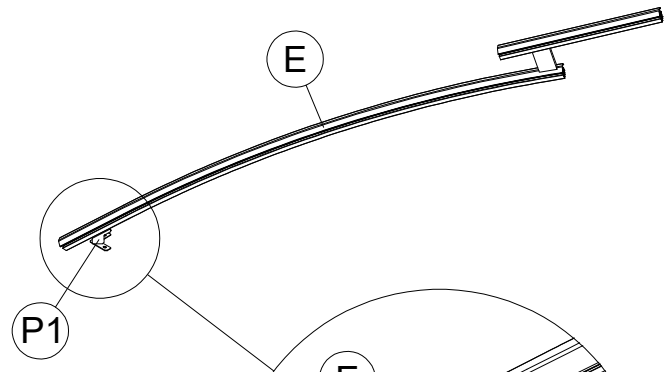

9



<7>

1

8x

M6x15

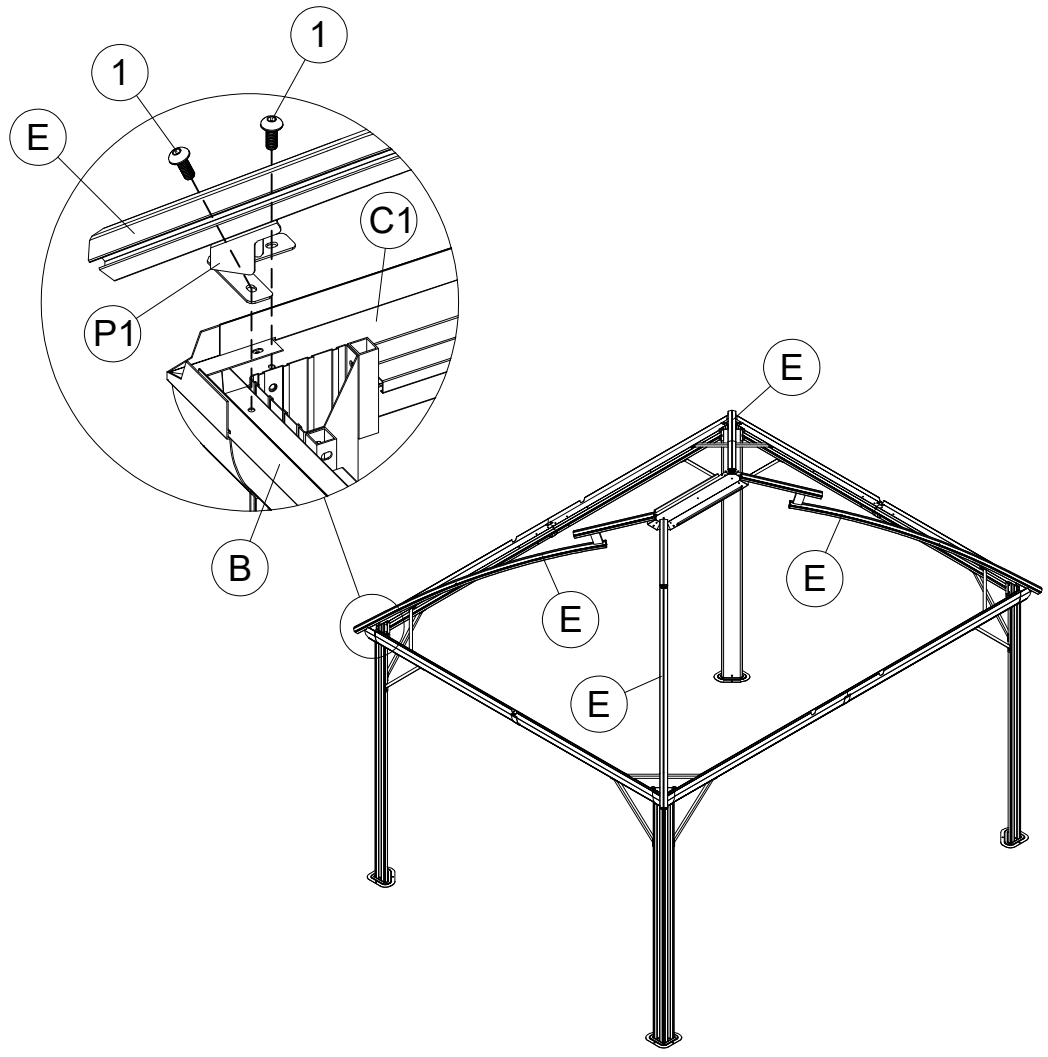

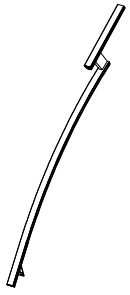

<8>

E1 6x



1 18x M6x15

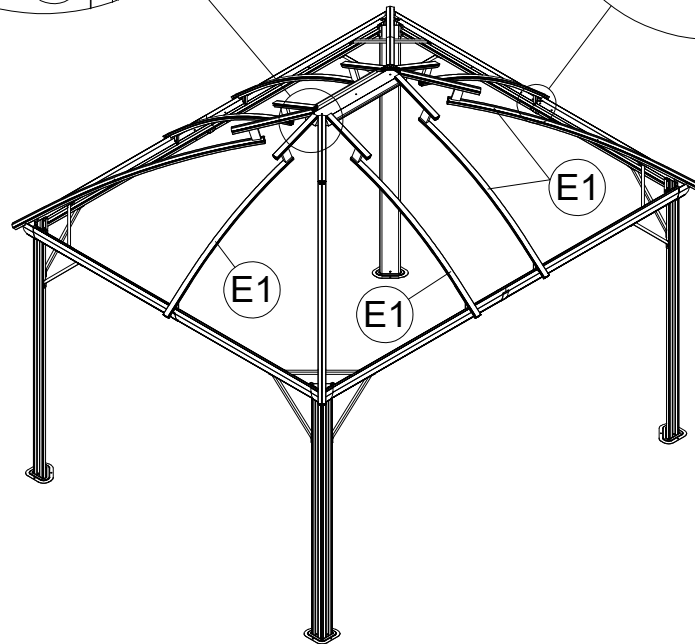
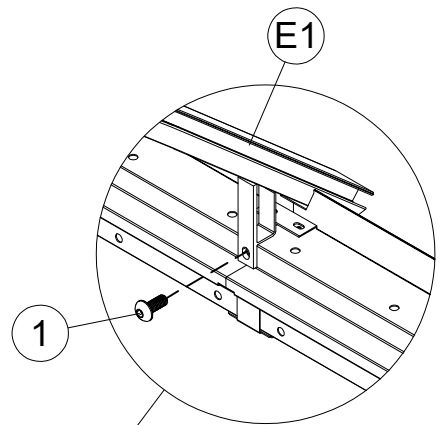
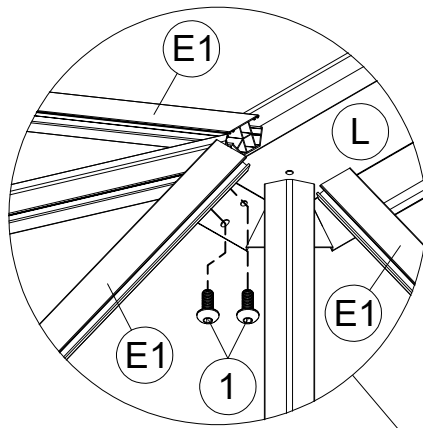

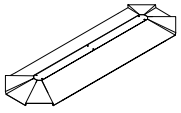

<9>

M 1x



1 1x M6x15



5 2x

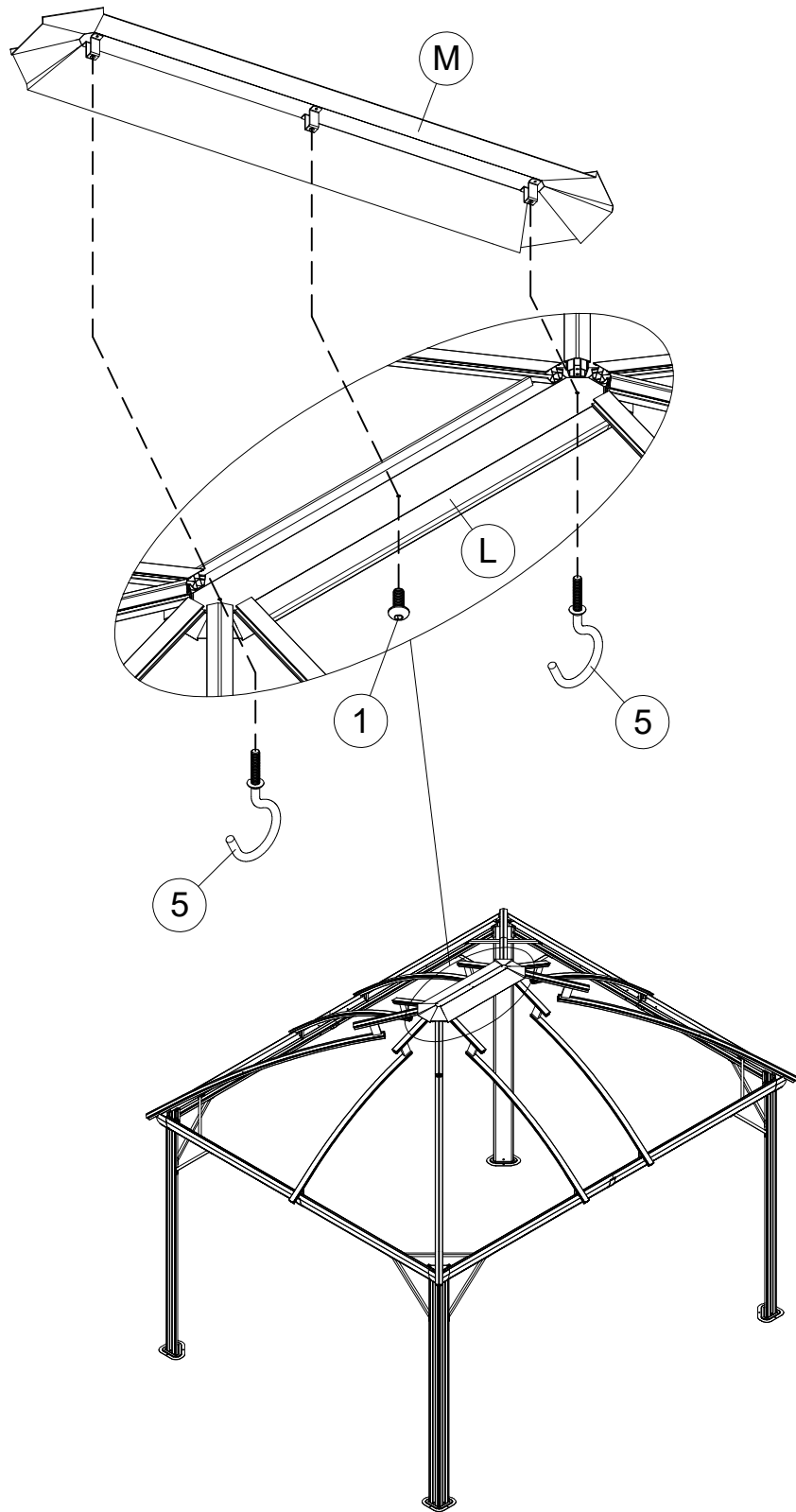

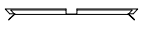

<10>

G3 2x

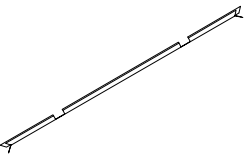

G4 2x



N4 4x



1 10x M6x15

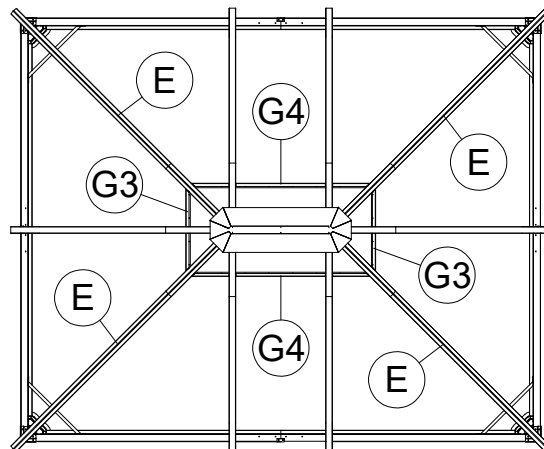
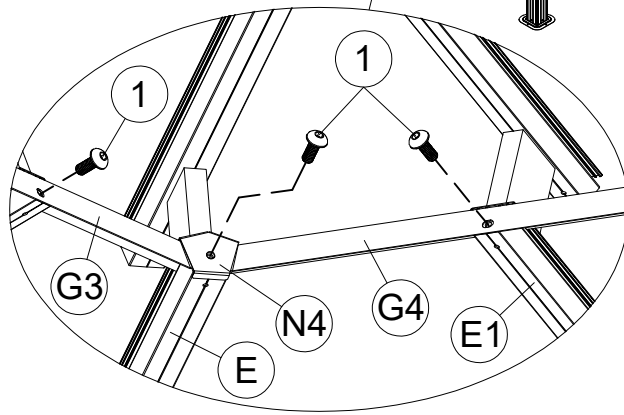
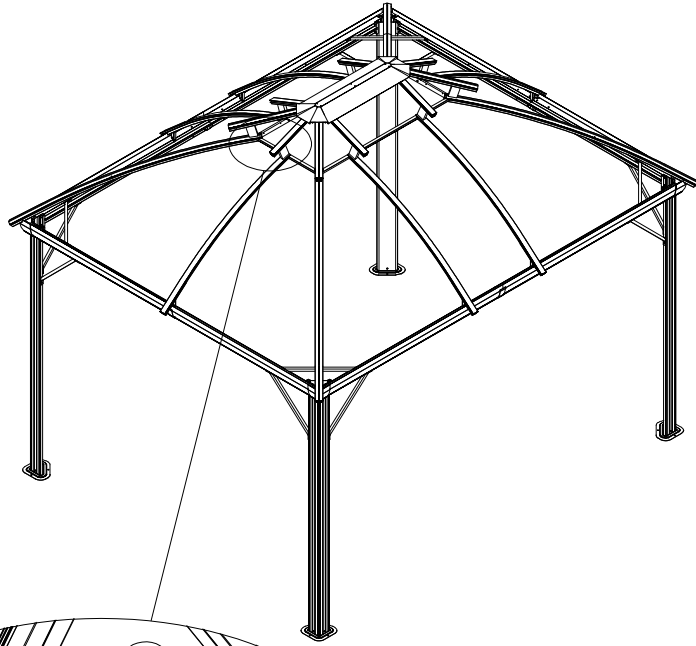

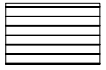

<11>

(S) 2x



(S1) 4x



(S2) 4x

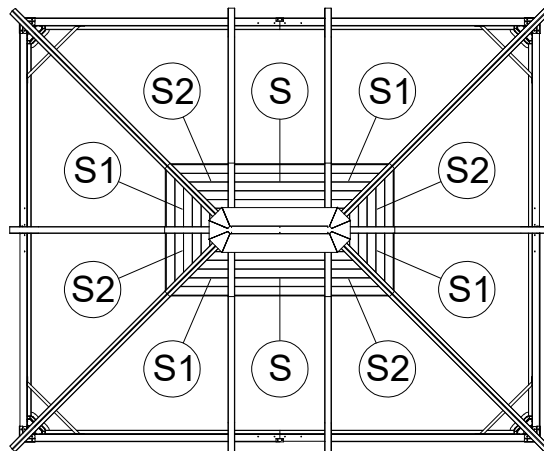
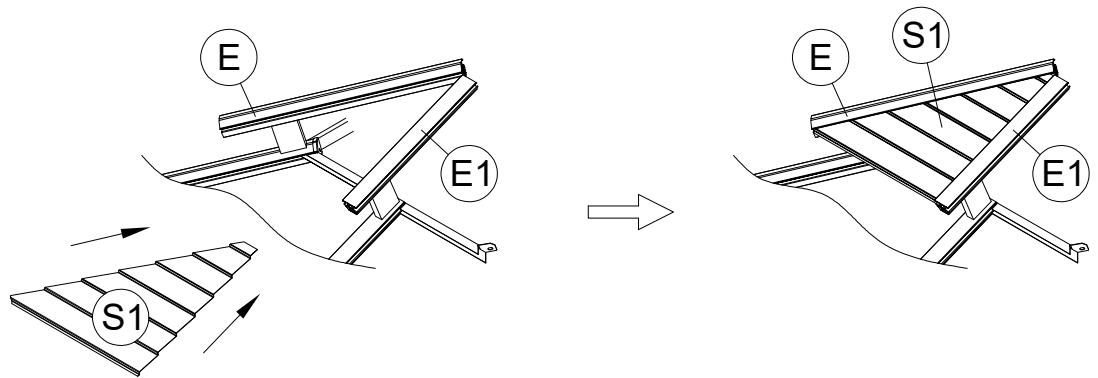
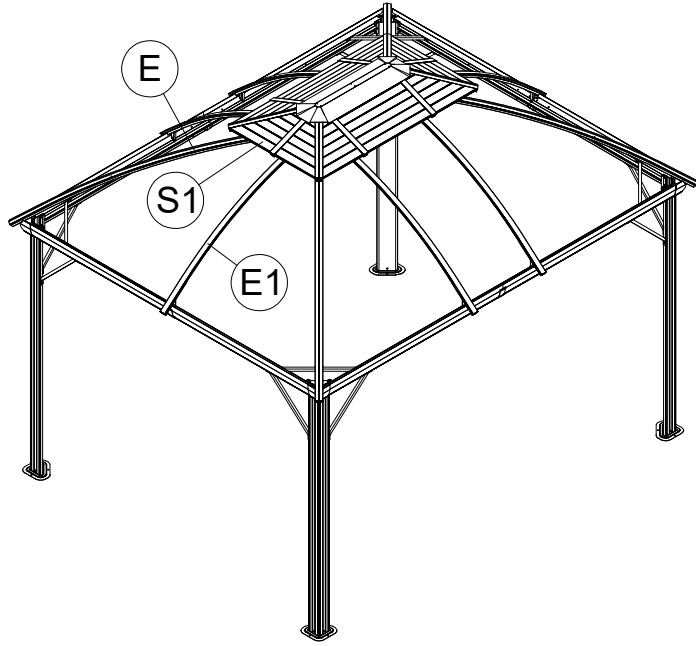

<12>

G 2x



D1 4x

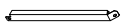

D2 4x



N4 4x



N1 6x



1 10x M6x15

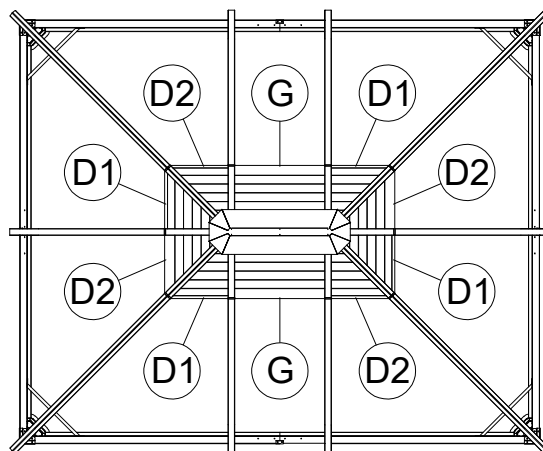
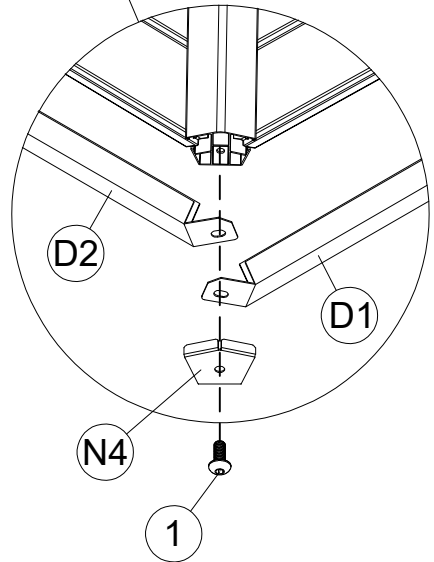
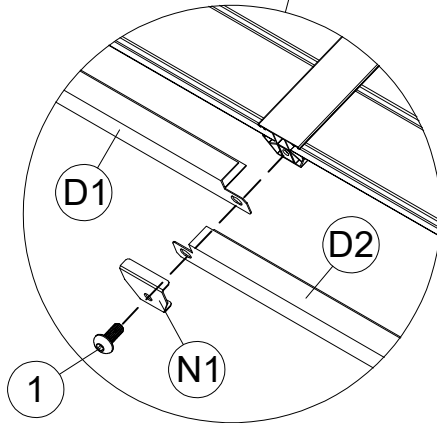
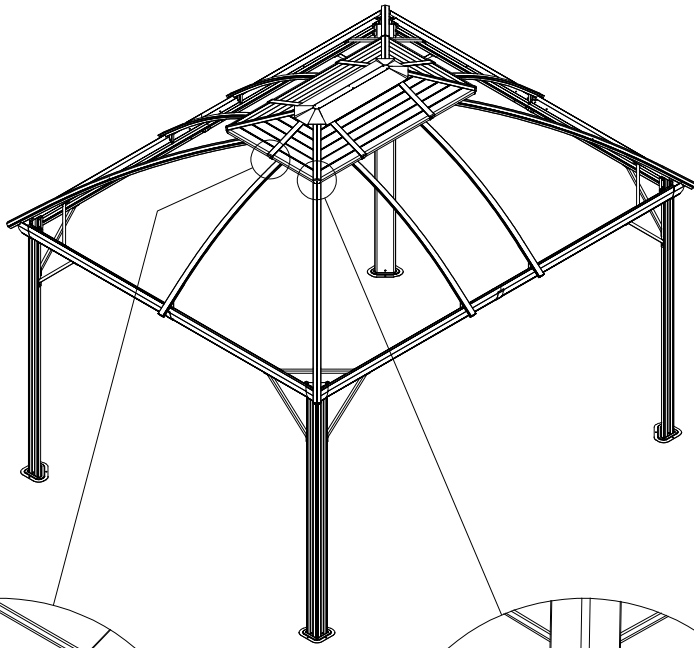

<13>

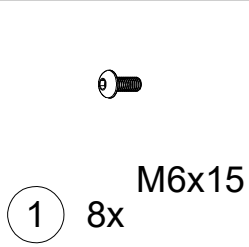
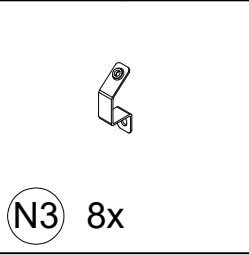
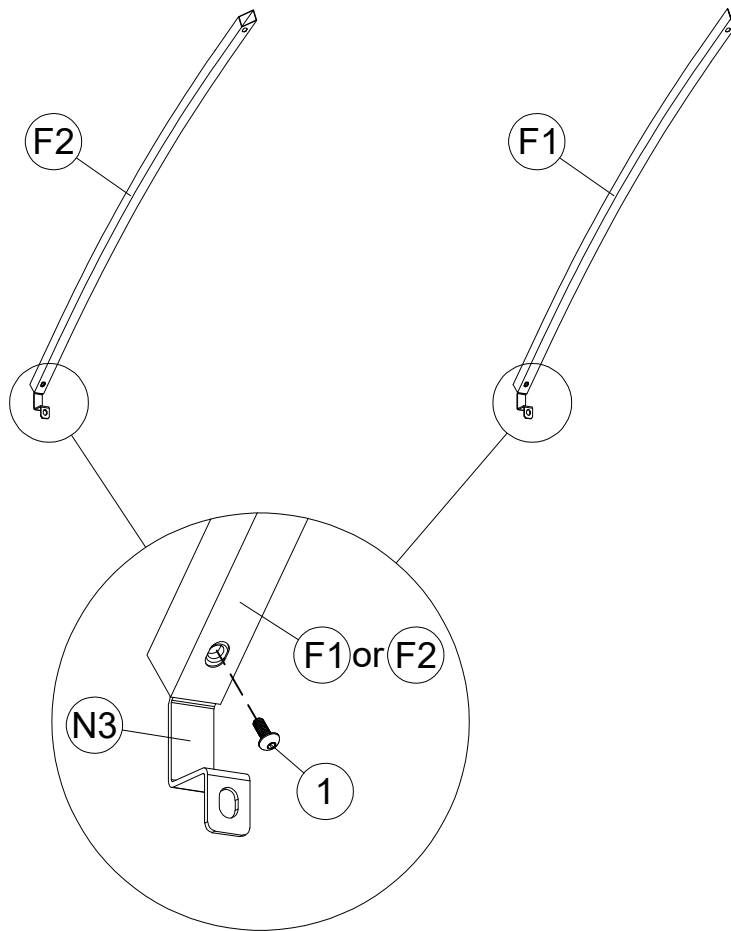
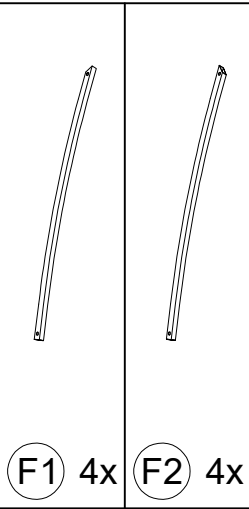

<14>

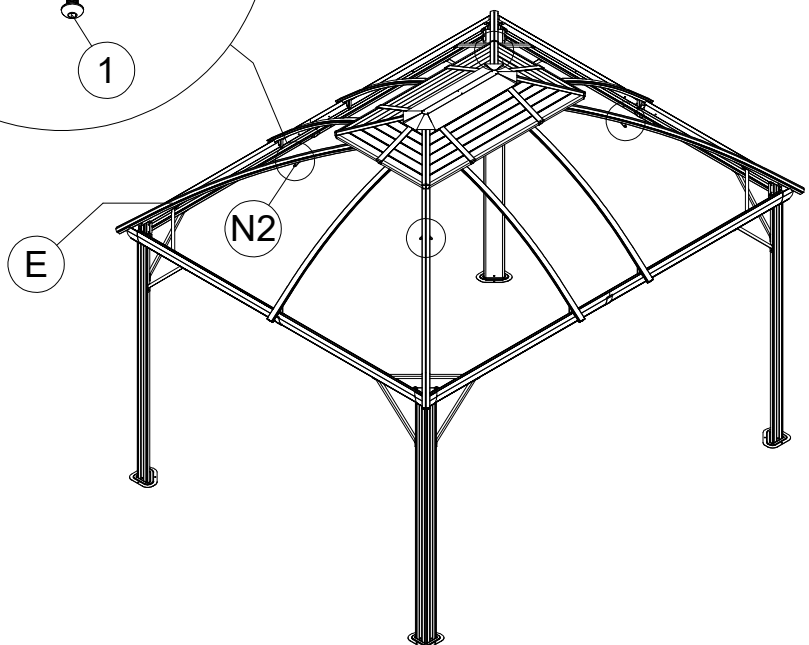
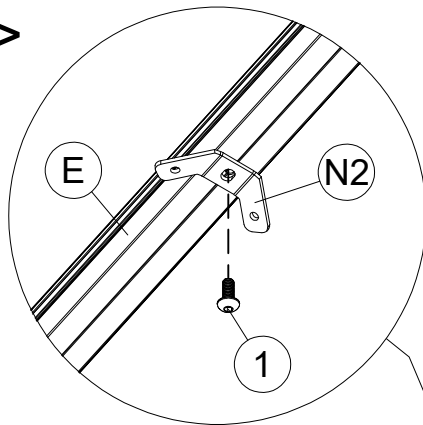
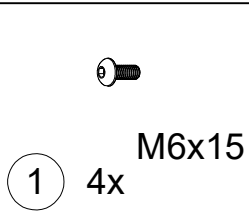
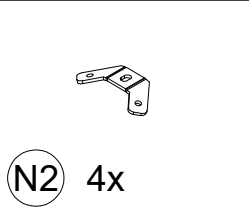



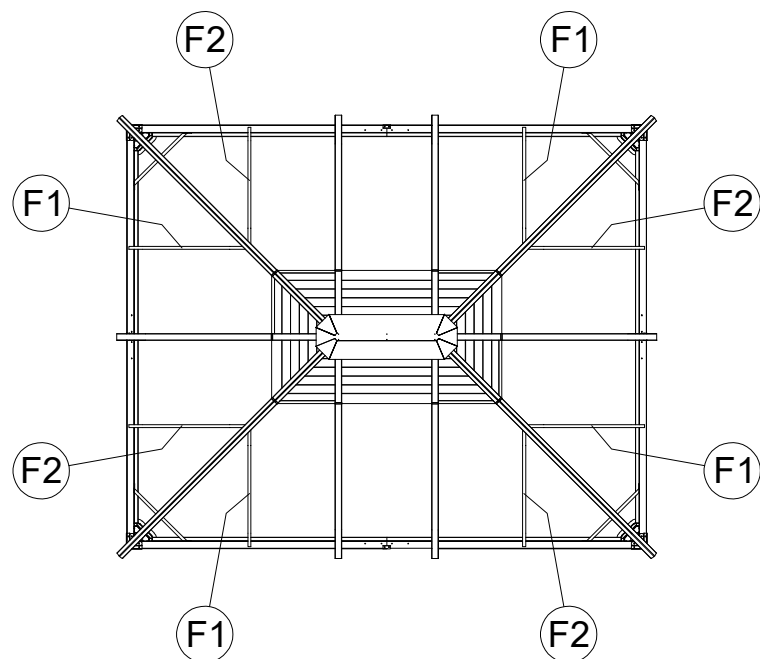
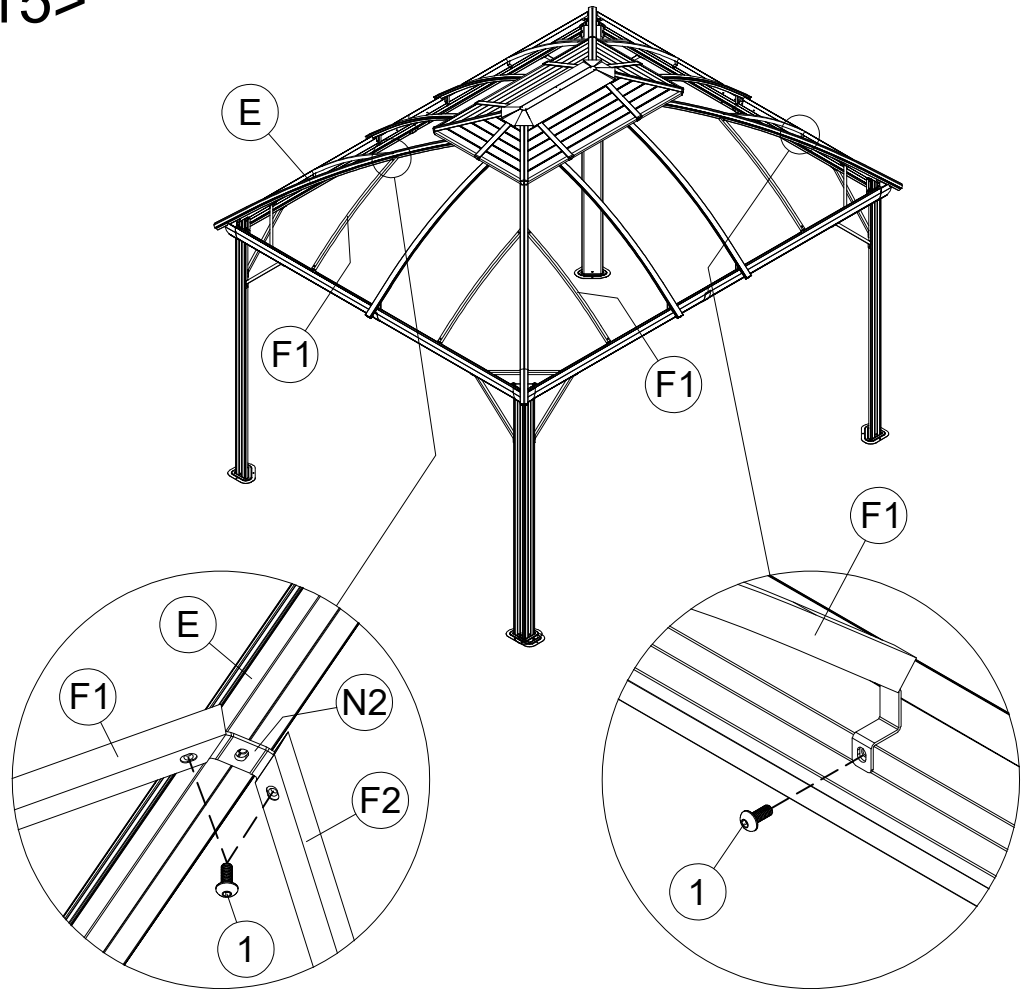

<15>

M6x15
1 16x

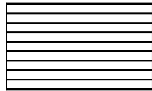
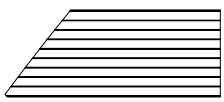
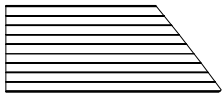
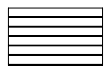
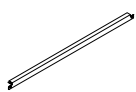
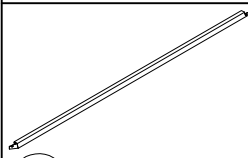
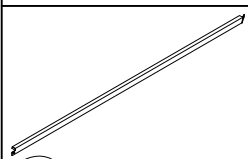

-  **Q** 4x
-  **Q1** 4x
-  **Q2** 4x
-  **R** 2x
-  **G** 2x
-  **G1** 4x
-  **G2** 4x
-  **Y** 8x
-  **N** 4x
- 18**

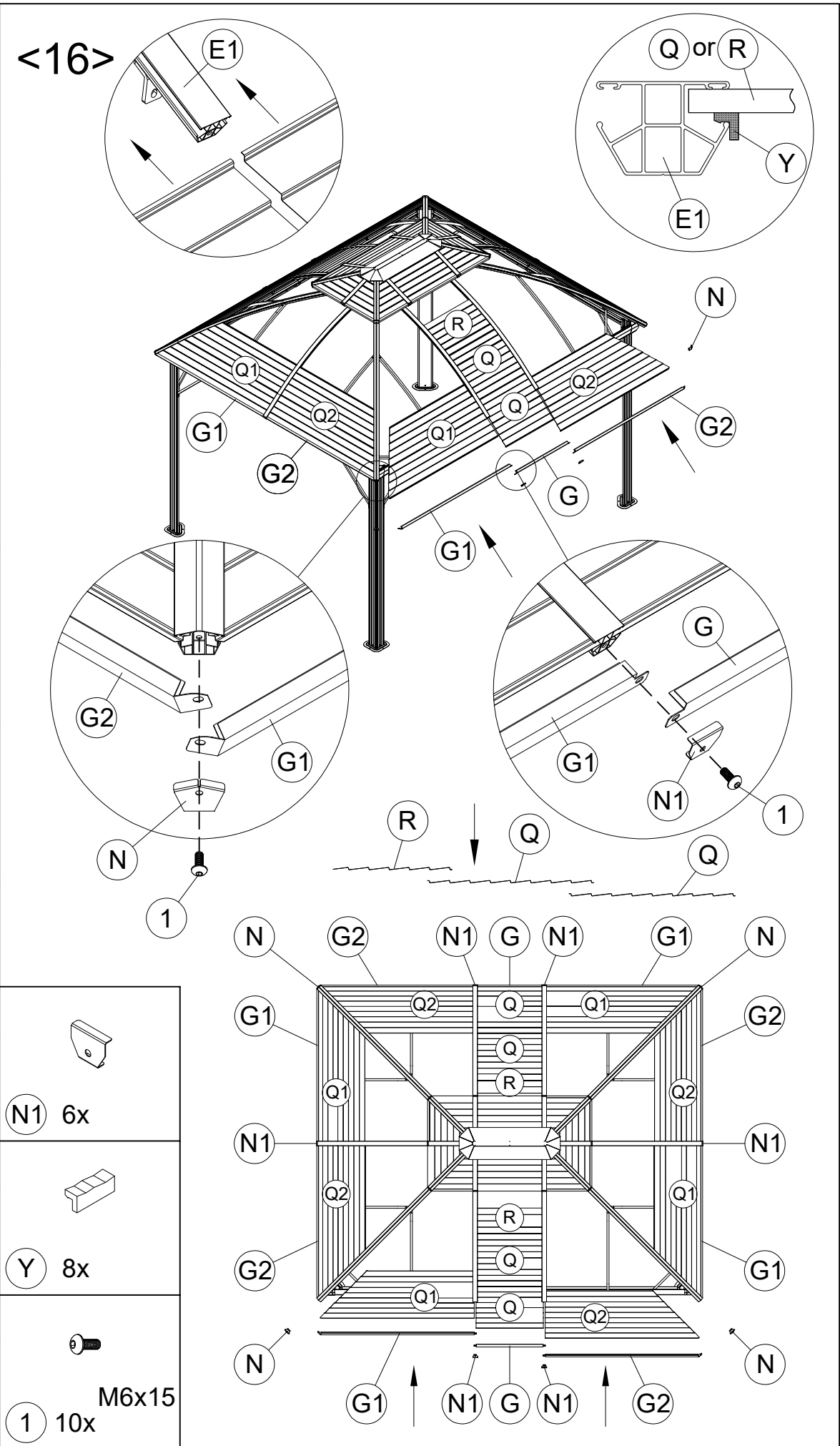

<17>

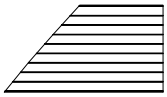

Q3 4x

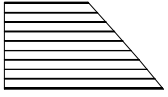

Q4 4x



Y 16x

Q3 or Q4

Q1 or Q2

E or E1

Y

EN_Note: Y is stuck in the position where the small piece (Q3,Q4) and the large piece (Q1,Q2) overlap.

FR_Note: Y est coincé dans la position où la petite pièce (Q3,Q4) et la grande pièce (Q1,Q2) se chevauchent.

ES_Nota: Y está atascado en la posición en la que la pieza pequeña (Q3,Q4) y la pieza grande (Q1,Q2) se solapan.

PT_Nota: Y está preso na posição em que a peça pequena (Q3,Q4) e a peça grande (Q1,Q2) se sobrepõem.

DE_Hinweis: Y bleibt in der Position stecken, in der sich die kleine Figur (Q3 Q4) und die große Figur (Q1, Q2) überschneiden.

IT_Nota: Y è bloccato nella posizione in cui il pezzo piccolo (Q3,Q4) e il pezzo grande (Q1,Q2) si sovrappongono.

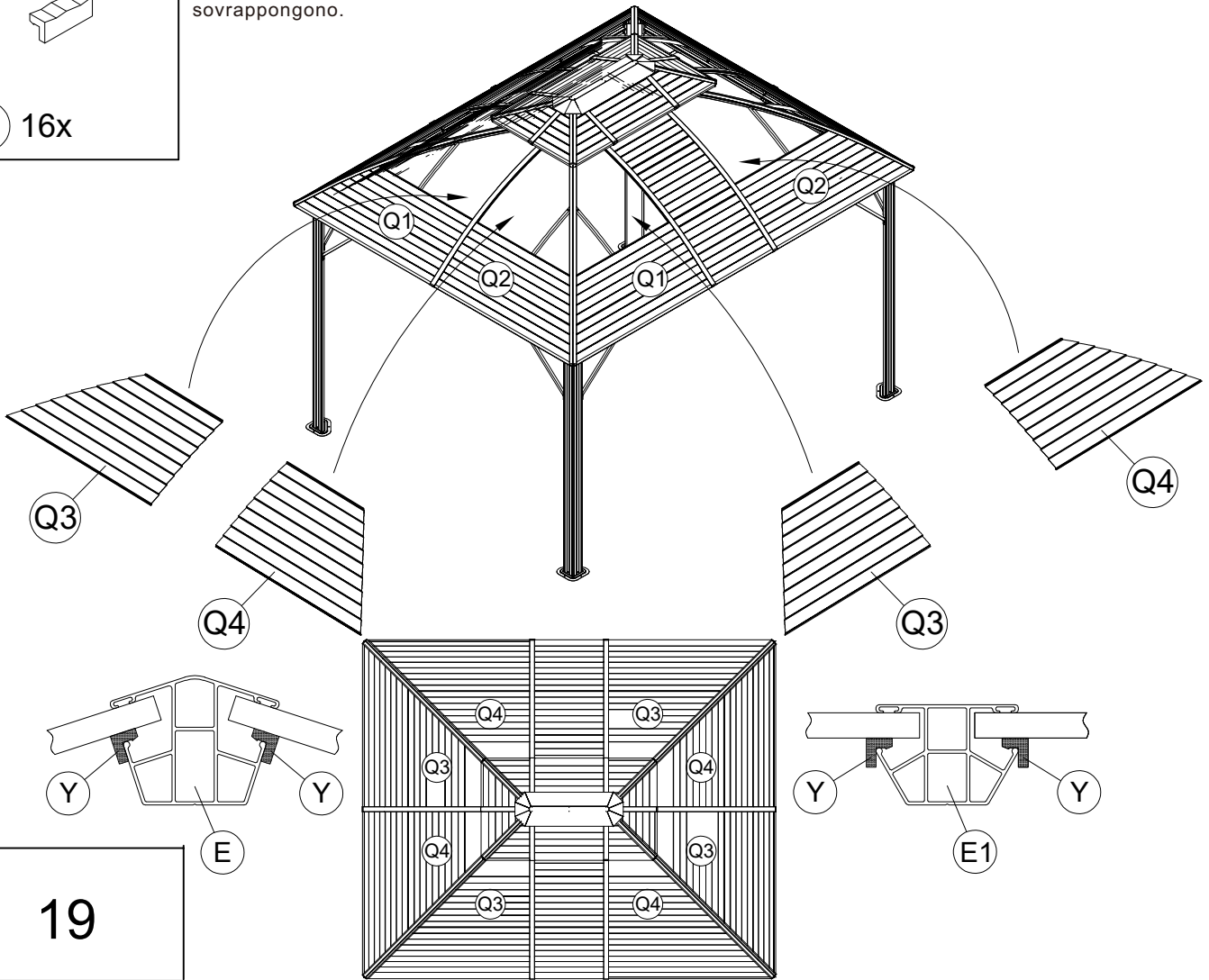
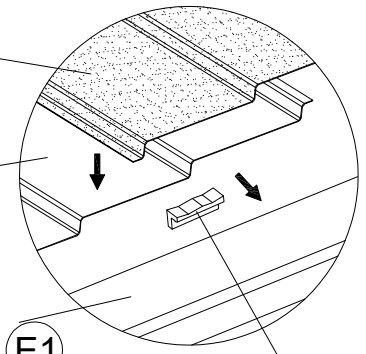

19

EN_Note: According to the installation order of (Q1,Q3) (Q2,Q4) is the best.

There is a small hole on the edge of each sheet of iron. This is only a hole, not a defect. The small hole is invisible after installation.

FR_Remarque: l'ordre d'installation (Q1,Q3) (Q2,Q4) est le meilleur.

Il y a un petit trou sur le bord de chaque feuille de fer. Il ne s'agit que d'un trou, pas d'un défaut. Le petit trou est invisible après l'installation.

ES_Nota: Según el orden de instalación de (Q1,Q3) (Q2,Q4) es el mejor.

Hay un pequeño agujero en el borde de cada hoja de hierro. Esto es sólo un agujero, no un defecto. El pequeño agujero es invisible después de la instalación.

PT_Nota: De acordo com a ordem de instalação de (Q1,Q3) (Q2,Q4) é a melhor.

Existe um pequeno orifício na extremidade de cada folha de ferro. Trata-se apenas de um buraco, não de um defeito. O pequeno orifício é invisível após a instalação.

DE_Hinweis: Entsprechend der Installationsreihenfolge (Q1,Q3) ist (Q2,Q4) am besten.

An der Kante jedes Eisenblechs befindet sich ein kleines Loch. Dabei handelt es sich nur um ein Loch, nicht um einen Defekt. Das kleine Loch ist nach der Installation nicht mehr sichtbar.

IT_Nota: l'ordine di installazione di (Q1,Q3) (Q2,Q4) è il migliore.

Sul bordo di ogni lastra di ferro è presente un piccolo foro. Si tratta solo di un foro, non di un difetto. Il piccolo foro è invisibile dopo l'installazione.

<18>

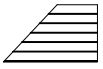

R1 4x

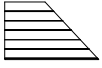

R2 4x



Y 16x

R1 or R2

Q3 or Q4

E or E1

Y

EN_Note: Y is stuck in the position where the small piece (R1,R2) and the large piece (Q3,Q4) overlap.

FR_Note: Y est coincé dans la position où la petite pièce (R1,R2) et la grande pièce (Q3,Q4) se chevauchent.

ES_Nota: Y está atascado en la posición en la que la pieza pequeña (R1,R2) y la pieza grande (Q3,Q4) se solapan.

PT_Nota: Y está preso na posição em que a peça pequena (R1,R2) e a peça grande (Q3,Q4) se sobrepõem.

DE_Hinweis: Y bleibt in der Position stecken, in der sich die kleine Figur (R1, R2) und die große Figur (Q3, Q4) überschneiden.

IT_Nota: Y è bloccato nella posizione in cui il pezzo piccolo (R1,R2) e il pezzo grande (Q3,Q4) si sovrappongono.

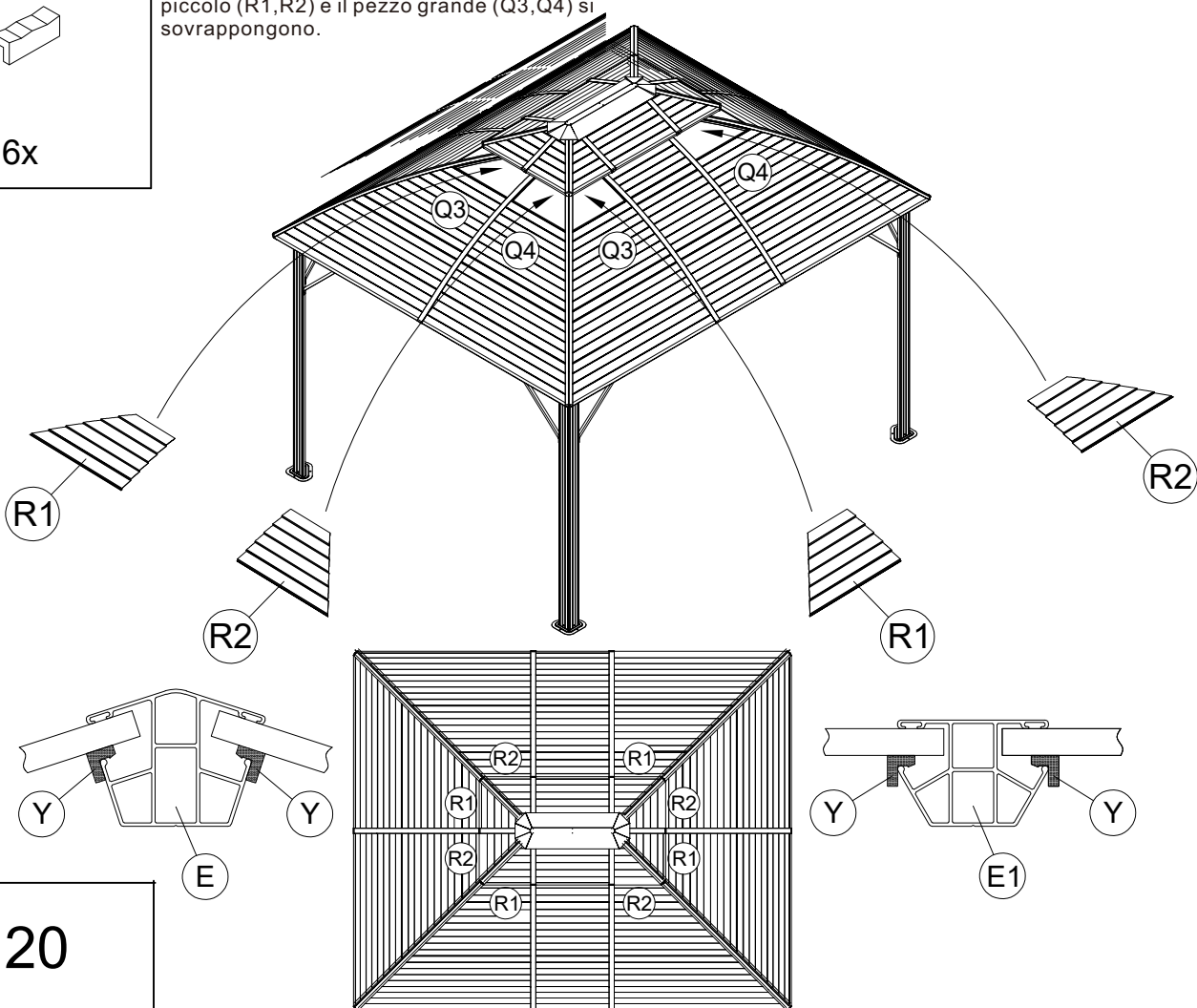
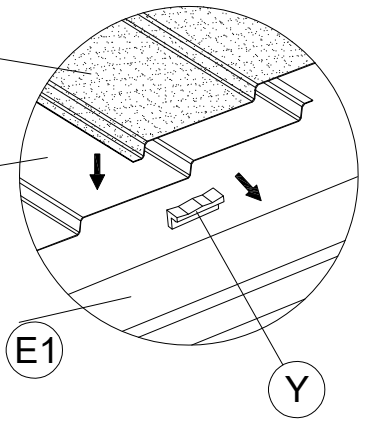

20

EN_Note: According to the installation order of (Q3,R1) (Q4,R2) is the best.

There is a small hole on the edge of each sheet of iron. This is only a hole, not a defect. The small hole is invisible after installation.

FR_Remarque: l'ordre d'installation (Q3,R1) (Q4,R2) est le meilleur.

Il y a un petit trou sur le bord de chaque feuille de fer. Il ne s'agit que d'un trou, pas d'un défaut. Le petit trou est invisible après l'installation.

ES_Nota: Según el orden de instalación de (Q3,R1) (Q4,R2) es el mejor.

Hay un pequeño agujero en el borde de cada hoja de hierro. Esto es sólo un agujero, no un defecto. El pequeño agujero es invisible después de la instalación.

PT_Nota: De acordo com a ordem de instalação de (Q3,R1) (Q4,R2) é a melhor.

Existe um pequeno orifício na extremidade de cada folha de ferro. Trata-se apenas de um buraco, não de um defeito. O pequeno orifício é invisível após a instalação.

DE_Hinweis: Entsprechend der Installationsreihenfolge (Q3,R1) ist (Q4,R2) am besten.

An der Kante jedes Eisenblechs befindet sich ein kleines Loch. Dabei handelt es sich nur um ein Loch, nicht um einen Defekt. Das kleine Loch ist nach der Installation nicht mehr sichtbar.

IT_Nota: l'ordine di installazione di (Q3,R1) (Q4,R2) è il migliore.

Sul bordo di ogni lastra di ferro è presente un piccolo foro. Si tratta solo di un foro, non di un difetto. Il piccolo foro è invisibile dopo l'installazione.

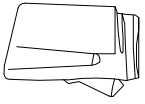

<19>

T 4x

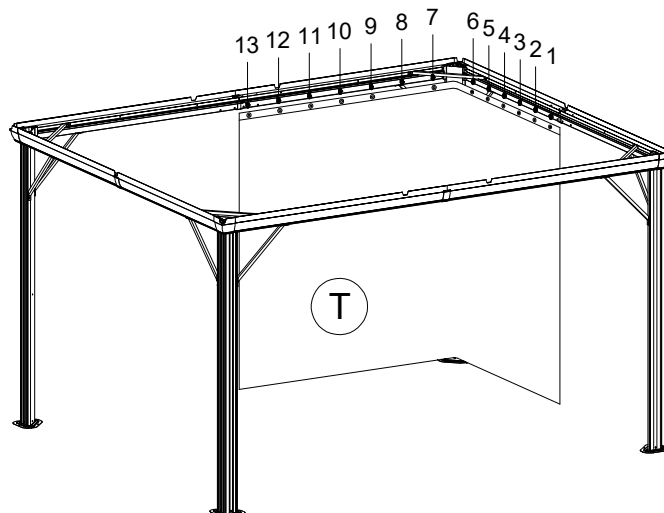
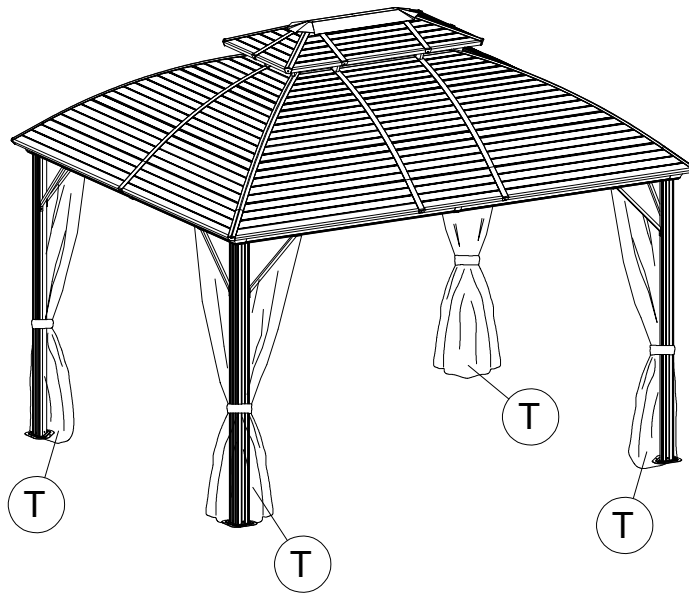
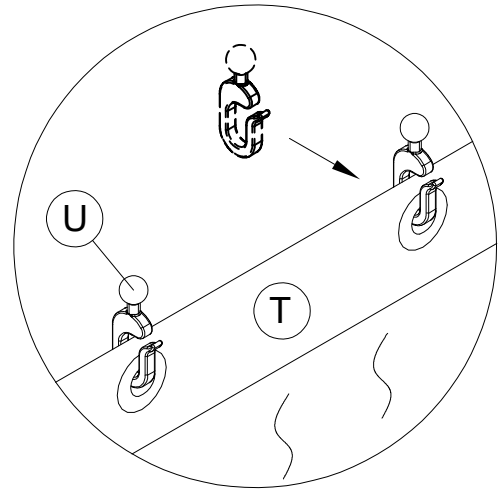
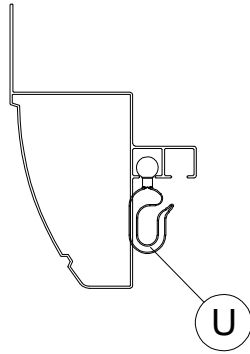

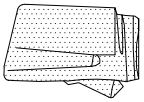

+



T1 4x + 1x

<20>

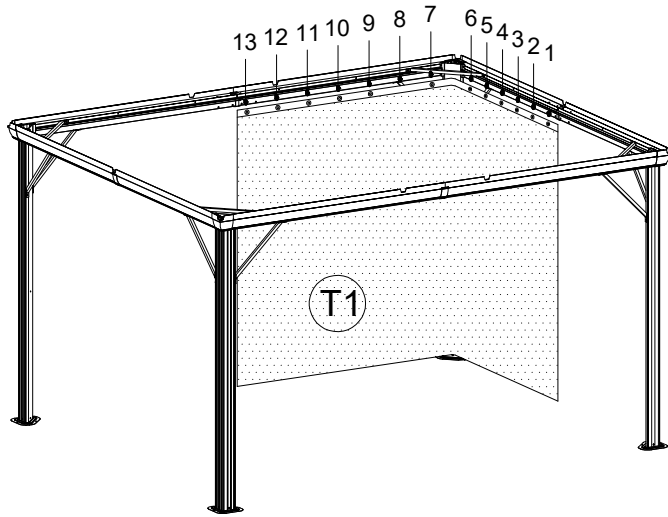
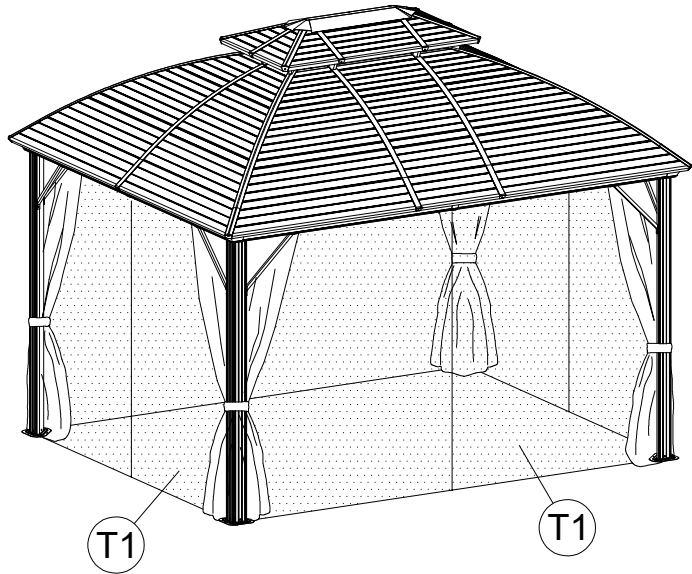
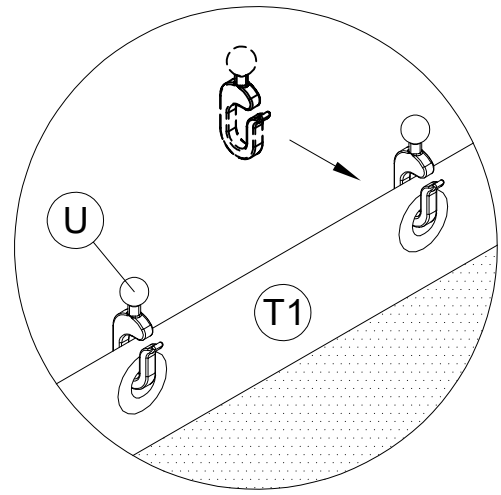
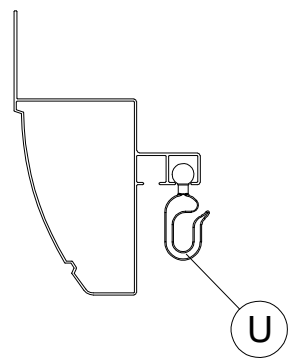
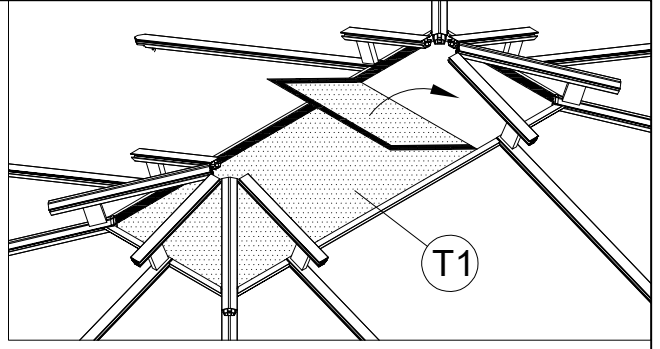



<21>

W 12x



8 12x

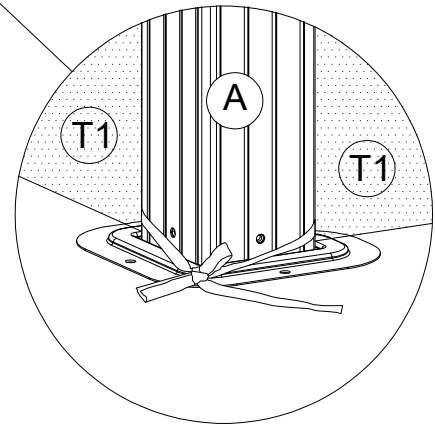
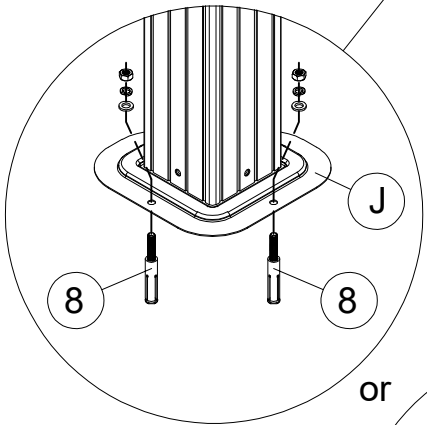
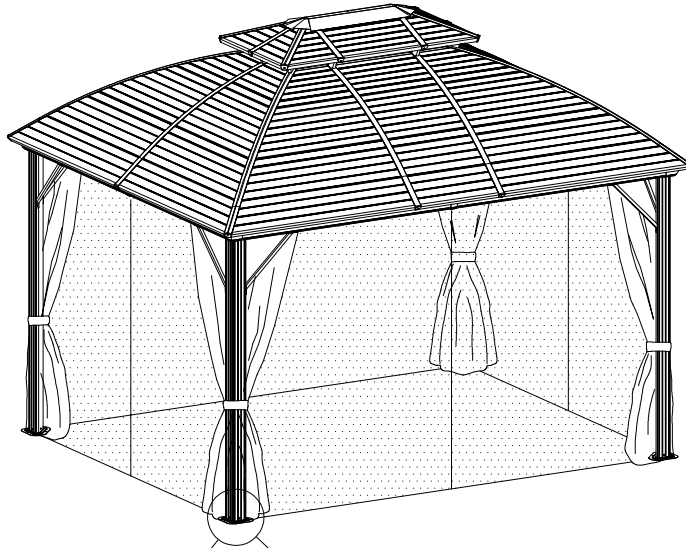

or

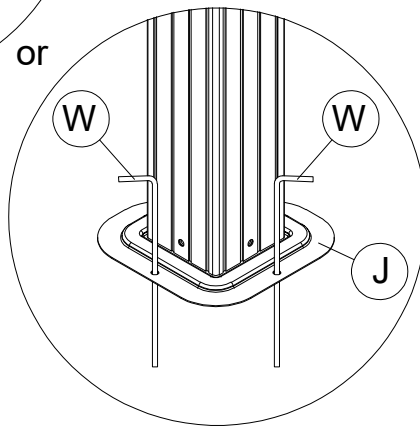

If you have any questions, please contact our customer care center, Our contact details are below:

US

 001-877-644-9366

 customerservice@aosom.com

Imported by Aosom LLC
27150 SW Kinsman Rd Wilsonville, OR 97070 USA
MADE IN CHINA

If you have any questions, please contact our customer care center, Our contact details are below:

CA

 416-792-6088

 customerservice@aosom.ca

Imported by Aosom Canada Inc.
7270 Woodbine Avenue, Unit 307, Markham,
Ontario Canada L3R 4B9
MADE IN CHINA

Si vous avez la moindre question, veuillez contacter notre centre d'assistance à la clientèle, Nos coordonnées sont les suivantes:

 416-792-6088

 customerservice@aosom.ca

Importé par Aosom Canada Inc.
7270 Woodbine Avenue, unité 307,
Markham, Ontario Canada L3R 4B9
FABRIQUÉ EN CHINE

If you have any questions, please contact our customer care center, Our contact details are below:

UK

 0044-800-240-4004

 enquiries@mhstar.co.uk

IMPORTER ADDRESS:
MH STAR UK LTD
Unit 27, Perivale Park,
Horsenden lane South
Perivale, UB6 7RH
MADE IN CHINA

Si vous avez la moindre question, veuillez contacter notre centre d'assistance à la clientèle, Nos coordonnées sont les suivantes:

 0033-1-84166106

 aosom@mhfrance.fr

Importé par/Fabricant/REP:
MH FRANCE
2 Rue Maurice Hartmann
92130 Issy Les Moulineaux
France
FABRIQUÉ EN CHINE

Wenn Sie Fragen haben, wenden Sie sich bitte an unser Kundendienstzentrum, Unsere Kontaktdaten stehen unten:

DE

 0049-0(40)-88307530

 service@aosom.de

ADRESSE DES IMPORTEURE/Hersteller/REP:
MH Handel GmbH
Wendenstraße 309
D-20537 Hamburg
Germany
IN CHINA HERGESTELLT

In caso di dubbio, si prega di contattare il nostro centro assistenza clienti, I nostri dettagli di contatto sono di seguito:

IT

 0039-0249471447

 clienti@aosom.it

IMPORTATO DA/Produttore/REP:
AOSOM Italy srl
Centro Direzionale Milanofiori
Strada 1 Palazzo F1
20057 Assago (MI)
P.I.: 08567220960
FATTO IN CINA

Si tiene alguna pregunta, comuníquese con nuestro Centro de Atención al Cliente, Nuestros datos de contacto son los siguientes:

ES

 0034-931294512

 atencioncliente@aosom.es

IMPORTADOR/Fabricante/REP:
SPANISH AOSOM, S.L.
C/ROC GROS, N°15.08550, ELS HOSTALETES DE
BALENYÀ, SPAIN.
B66295775
HECHO EN CHINA

Se tiver alguma dúvida, por favor contacte o nosso Centro de Atendimento ao Cliente, Os nossos dados de contacto são os seguintes:

PT

 0034-931294512

 info@aosom.pt.

IMPORTADOR/Fabricante/REP:
SPANISH AOSOM, S.L.
C.ROC GROS N.15, 08550. ELS HOSTALETES DE
BALENYÀ
FEITO NA CHINA

Si vous avez la moindre question, veuillez contacter notre centre d'assistance à la clientèle, Nos coordonnées sont les suivantes:

FR

 0033-1-84166106

 aosom@mhfrance.fr

Importé par/Fabricant/REP:
MH FRANCE
2 Rue Maurice Hartmann
92130 Issy Les Moulineaux
France
FABRIQUÉ EN CHINE



FR

**DONNEZ
OU
RECYCLEZ**



ASSOCIATION

OU



LIVRAISON

OU



DÉCHÈTERIE

Adresses sur quefairedemesdechets.fr